

Abstractive Summarization of Social Media Posts

A case study using deep learning

Master Thesis
(Shahbaz Syed)

Bauhaus-Universität Weimar

Examiners:

Prof. Dr. Benno Stein
Prof. Dr. Andreas Jakoby

Supervisors :

Michael Voelske
Dr. Martin Potthast





Motivation



Motivation



Everyday

	4 Billion messages
	500 Million tweets
	200 Billion emails
	3.4 Million blogs

Motivation

Extractive vs Abstractive

The Army Corps of Engineers, rushing to meet President Bush's promise to protect New Orleans by the start of the 2006 hurricane season, installed defective flood-control pumps last year despite warnings from its own expert that the equipment would fail during a storm, according to documents obtained by The Associated Press.

Motivation

Extractive vs Abstractive

The **Army Corps of Engineers**, rushing to meet **President Bush's** promise to protect **New Orleans** by the start of the 2006 hurricane season, installed **defective flood-control pumps** last year despite warnings from its own expert that the equipment would fail during a storm, according to documents obtained by The Associated Press.

Extractive : “Army Corps of Engineers,” “President Bush,” “New Orleans,” and “defective flood-control pumps”

Motivation

Extractive vs Abstractive

The Army Corps of Engineers, rushing to meet President Bush's promise to protect New Orleans by the start of the 2006 hurricane season, installed defective flood-control pumps last year despite warnings from its own expert that the equipment would fail during a storm, according to documents obtained by The Associated Press.

Extractive : “Army Corps of Engineers,” “President Bush,” “New Orleans,” and “defective flood-control pumps”

Abstractive : “political negligence” , “inadequate protection from floods”

Motivation

Why abstractive using deep learning?

Motivation

Why abstractive using deep learning?

- Automatic feature learning

Motivation

Why abstractive using deep learning?

- Automatic feature learning
- Large amounts of data available compliments deep learning models

Motivation

Why abstractive using deep learning?

- Automatic feature learning
- Large amounts of data available compliments deep learning models
- Low dependency on domain of the texts

Motivation

Why abstractive using deep learning?

- Automatic feature learning
- Large amounts of data available compliments deep learning models
- Low dependency on domain of the texts
- Abstractive summaries are more appealing than text extracts

Motivation

Challenges

Motivation

Challenges

- Deep learning models need clean datasets

Motivation

Challenges

- Deep learning models need clean datasets
- Lack of variety in available datasets

Dataset	Size	Domain
Gigaword	4 Million	News
CNN / DailyMail	110,000	News

Motivation

Challenges

- Deep learning models need clean datasets
- Lack of variety in available datasets

Dataset	Size	Domain
Gigaword	4 Million	News
CNN / DailyMail	110,000	News

- Current evaluation measure (ROUGE) may not be suitable for abstractive summaries

Contributions

Contributions

- **Webis-TLDR-17 corpus** for summarization from the social media domain (Reddit)

Contributions

- **Webis-TLDR-17 corpus** for summarization from the social media domain (Reddit)
- Exploring the effectiveness and limitations of a *specific model* for abstractive summarization

Contributions

- **Webis-TLDR-17 corpus** for summarization from the social media domain (Reddit)
- Exploring the effectiveness and limitations of a *specific model* for abstractive summarization
- Advocating a need for a better evaluation method than ROUGE for judging abstractive summaries

Reddit



COMMENTS

527

What are the most ridiculous things you believed to be true as a child? (self:AskReddit)

submitted 1 month ago by IfIHadANickle4UsAll

1000 comments share report

[-] **Lostsonofpluto** 129 points 1 month ago

My dad spent the better part of his childhood believing his early memories of his family having a pet monkey were just something his kid brain made up. When he asked his parents it turned out they actually did have one and that they gave it to a local zoo before his sister was born.

TL;DR

My dad believed his family didn't have a pet monkey

[permalink](#) [embed](#) [report](#)

[load more comments](#) (2 replies)



askreddit

Sub-reddit

COMMENTS

527

What are the most ridiculous things you believed to be true as a child? (self.AskReddit)

submitted 1 month ago by IfIHadANickle4UsAll

1000 comments share report

[-] **Lostsonofpluto** 129 points 1 month ago

My dad spent the better part of his childhood believing his early memories of his family having a pet monkey were just something his kid brain made up. When he asked his parents it turned out they actually did have one and that they gave it to a local zoo before his sister was born.

TL;DR

My dad believed his family didn't have a pet monkey

[permalink](#) [embed](#) [report](#)

[load more comments](#) (2 replies)



askreddit

Sub-reddit

COMMENTS

527

What are the most ridiculous things you believed to be true as a child? (self.AskReddit)

Submission

submitted 1 month ago by IfIHadANickle4UsAll
1000 comments share report

[-] **Lostsonofpluto** 129 points 1 month ago

My dad spent the better part of his childhood believing his early memories of his family having a pet monkey were just something his kid brain made up. When he asked his parents it turned out they actually did have one and that they gave it to a local zoo before his sister was born.

TL;DR

My dad believed his family didn't have a pet monkey

[permalink](#) [embed](#) [report](#)

[load more comments](#) (2 replies)



askreddit

Sub-reddit

COMMENTS

527

What are the most ridiculous things you believed to be true as a child? (self.AskReddit)

Submission

submitted 1 month ago by IfIHadANickle4UsAll
1000 comments share report

[-] **Lostsonofpluto** 129 points 1 month ago

My dad spent the better part of his childhood believing his early memories of his family having a pet monkey were just something his kid brain made up. When he asked his parents it turned out they actually did have one and that they gave it to a local zoo before his sister was born.

TL;DR

My dad believed his family didn't have a pet monkey

permalink embed report

Comment

load more comments (2 replies)



askreddit

Sub-reddit

COMMENTS

527

What are the most ridiculous things you believed to be true as a child? (self.AskReddit)

Submission

submitted 1 month ago by IfIHadANickle4UsAll
1000 comments share report

[-] **Lostsonofpluto** 129 points 1 month ago

My dad spent the better part of his childhood believing his early memories of his family having a pet monkey were just something his kid brain made up. When he asked his parents it turned out they actually did have one and that they gave it to a local zoo before his sister was born.

TL;DR

My dad believed his family didn't have a pet monkey

permalink embed report

Comment

load more comments (2 replies)

Webis-TLDR-17 Corpus

Corpus creation pipeline

Corpus creation pipeline

- Check for presence of `tl.{0,3}dr`

Corpus creation pipeline

- Check for presence of **tl.{0,3}dr**

Example 1

so every student in the world seems to be moving today, i've just been roped into playing van-driver for another couple.
but it did get me thinking; if any of you leeds (ish) peeps are desperate to last-minute move some stuff, you should probably send me a pm and we can try and move a van-load this afternoon.

tldr: need van this afternoon? pm me a phone number i can sms.

Example 2

kinda drunk:

so i did lie this girl who and i drank a little to much tonight and i kinda told jher i like her and esked her if she felt the same way. she said that is looking for a father figure (she has 2 kids) i said i comepletly understand that and now i move you from the sex list to the awesome fire nd list. and she said that she was happy wityh how i said that. i hope i didnt screw theis freind ship up casue she really is a n aawesome person.

tl/druijksd

areyouhumasn

is hard to spoelll wihen you are drubnk

Corpus creation pipeline

- Check for presence of `tl.{0,3}dr`
- **Remove** posts by bots

Corpus creation pipeline

- Check for presence of `tl.{0,3}dr`
- **Remove** posts by bots
- **Remove** posts with multiple occurrences of `tl.{0,3}dr`

Corpus creation pipeline

- Check for presence of `tl.{0,3}dr`
- **Remove** posts by bots
- **Remove** posts with multiple occurrences of `tl.{0,3}dr`
- **Preserve** posts containing relevant `tl.{0,3}dr` patterns

Corpus creation pipeline

- Check for presence of `tl.{0,3}dr`
- **Remove** posts by bots
- **Remove** posts with multiple occurrences of `tl.{0,3}dr`
- **Preserve** posts containing relevant `tl.{0,3}dr` patterns
- **Remove** cases where content is shorter than the summary

Corpus creation pipeline

- Check for presence of **tl.{0,3}dr**
- **Remove** posts by bots
- **Remove** posts with multiple occurrences of **tl.{0,3}dr**
- **Preserve** posts containing relevant **tl.{0,3}dr** patterns
- **Remove** cases where content is shorter than the summary
- **Preserve** posts with minimum length of **content 2 words , summary 1 word**

Remove posts by bots

your submission has been automatically removed because it does not appear to contain a **tl;dr** or any sort of short summary.

please edit your post to add a (preferably ****bolded****) **tl;dr**, ensure that it meets all the other requirements (includes the ages of the people involved and length of relationship) and then [message the moderators](<http://www.reddit.com/message/compose?to=%2fr%2frelationships&subject=please+reapprove>) to have it re-approved. if your post already contained a tl;dr, please let us know so that we can improve our systems.

***i am a bot, and this action was performed automatically.** please [contact the moderators of this subreddit](<http://www.reddit.com/message/compose?to=%23relationships>) if you have any questions or concerns.*

Remove posts with multiple **tl;dr** occurrences

I would expect anyone likely to post "**tl;dr**" wouldn't subscribe to the subreddit, as it would be made clear that long-form content was contained within. It's too bad there isn't some way to make it so that Reddit gives a user an electric shock when they type **tl;dr** really. Such people should be very ashamed of themselves, bragging about being too lazy (practically and intellectually) to read a detailed comment. I can understand if you don't have the time or motivation to put forth the effort... but to post a comment pointing it out? That's an act of sheer pride in ignorance.

Remove posts with multiple **tl;dr** occurrences

I would expect anyone likely to post "**tl;dr**" wouldn't subscribe to the subreddit, as it would be made clear that long-form content was contained within. It's too bad there isn't some way to make it so that Reddit gives a user an electric shock when they type **tl;dr** really. Such people should be very ashamed of themselves, bragging about being too lazy (practically and intellectually) to read a detailed comment. I can understand if you don't have the time or motivation to put forth the effort... but to post a comment pointing it out? That's an act of sheer pride in ignorance.

Preserve relevant **tl.{0,3}dr** patterns

tl;dr	count(tl;dr)
tl;dr	984131
tl;dr	285607
tl:dr	75734
tly dr	25307
tl/dr	15893
tle dr	15432
tl; dr	10934
tl,dr	7851
tl dr	3943
tl, dr	1339
tl'dr	1037
tl-dr	910
tly, dr	832
tlsdr	553
tl-sdr	526
tle, dr	510

Preserve relevant **tl.{0,3}dr** patterns

tl;dr	count(tl;dr)
tl;dr	984131
tldr	285607
tl:dr	75734
tly dr	25307
tl/dr	15893
tle dr	15432
tl; dr	10934
tl,dr	7851
tl dr	3943
tl, dr	1339
tl'dr	1037
tl-dr	910
tly, dr	832
tlsdr	553
tl-sdr	526
tle, dr	510



COMMENTS

527

What are the most ridiculous things you believed to be true as a child? (self:AskReddit)

submitted 1 month ago by IfIHadANickle4UsAll

1000 comments share report

[-] **Lostsonofpluto** 129 points 1 month ago

My dad spent the better part of his childhood believing his early memories of his family having a pet monkey were just something his kid brain made up. When he asked his parents it turned out they actually did have one and that they gave it to a local zoo before his sister was born.

TL;DR

My dad believed his family didn't have a pet monkey

[permalink](#) [embed](#) [report](#)

[load more comments](#) (2 replies)



COMMENTS

527

What are the most ridiculous things you believed to be true as a child? (self:AskReddit)

submitted 1 month ago by IfIHadANickle4UsAll

1000 comments share report

[-] **Lostsonofpluto** 129 points 1 month ago

My dad spent the better part of his childhood believing his early memories of his family having a pet monkey were just something his kid brain made up. When he asked his parents it turned out they actually did have one and that they gave it to a local zoo before his sister was born. ←

TL;DR

My dad believed his family didn't have a pet monkey

[permalink](#) [embed](#) [report](#)

[load more comments](#) (2 replies)



COMMENTS

527

What are the most ridiculous things you believed to be true as a child? (self:AskReddit)

submitted 1 month ago by IfIHadANickle4UsAll

1000 comments share report

[-] **Lostsonofpluto** 129 points 1 month ago

My dad spent the better part of his childhood believing his early memories of his family having a pet monkey were just something his kid brain made up. When he asked his parents it turned out they actually did have one and that they gave it to a local zoo before his sister was born. ←

TL;DR ←

My dad believed his family didn't have a pet monkey

permalink embed report

load more comments (2 replies)



COMMENTS

527

What are the most ridiculous things you believed to be true as a child? (self.AskReddit)

submitted 1 month ago by IfIHadANickle4UsAll

1000 comments share report

[-] **Lostsonofpluto** 129 points 1 month ago

My dad spent the better part of his childhood believing his early memories of his family having a pet monkey were just something his kid brain made up. When he asked his parents it turned out they actually did have one and that they gave it to a local zoo before his sister was born. ←

TL;DR ←

→ My dad believed his family didn't have a pet monkey

permalink embed report

load more comments (2 replies)



COMMENTS

527

What are the most ridiculous things you believed to be true as a child? (self.AskReddit)

submitted 1 month ago by IfIHadANickle4UsAll

1000 comments share report

[-] **Lostsonofpluto** 129 points 1 month ago

My dad spent the better part of his childhood believing his early memories of his family having a pet monkey were just something his kid brain made up. When he asked his parents it turned out they actually did have one and that they gave it to a local zoo before his sister was born. ←

TL;DR ←

→ My dad believed his family didn't have a pet monkey

permalink embed report

load more comments (2 replies)

Precision of **96%** was achieved for **2000** examples manually evaluated

[source](#)

Filtering process - Base corpus

Filtering step	Submissions	Comments
Raw input	286,168,475 (286 Million)	1,659,361,727 (1.6 Billion)
Contains a tl.{0,3}dr	2,079,035	3,745,320
Non-bot posts	1,969,413	3,351,597
Contains a valid tl;dr	1,829,030	2,987,135
Final pairs (C2, S1)	1,658,567 (~ 1.6 Million)	2,189,763 (~ 2.1 Million)

Filtering process - Base corpus

Filtering step	Submissions	Comments
Raw input	286,168,475 (286 Million)	1,659,361,727 (1.6 Billion)
Contains a tl.{0,3}dr	2,079,035	3,745,320
Non-bot posts	1,969,413	3,351,597
Contains a valid tl;dr	1,829,030	2,987,135
Final pairs (C2, S1)	1,658,567 (~ 1.6 Million)	2,189,763 (~ 2.1 Million)

Filtering process - Base corpus

Filtering step	Submissions	Comments
Raw input	286,168,475 (286 Million)	1,659,361,727 (1.6 Billion)
Contains a tl.{0,3}dr	2,079,035	3,745,320
Non-bot posts	1,969,413	3,351,597
Contains a valid tl;dr	1,829,030	2,987,135
Final pairs (C2, S1)	1,658,567 (~ 1.6 Million)	2,189,763 (~ 2.1 Million)

Filtering process - Base corpus

Filtering step	Submissions	Comments
Raw input	286,168,475 (286 Million)	1,659,361,727 (1.6 Billion)
Contains a tl.{0,3}dr 	2,079,035	3,745,320
Non-bot posts	1,969,413	3,351,597
Contains a valid tl;dr	1,829,030	2,987,135
Final pairs (C2, S1)	1,658,567 (~ 1.6 Million)	2,189,763 (~ 2.1 Million)

Corpus verticals

One purpose - One tl;dr

- Questions
- Vulgar posts
- True summaries
- Topic + tl;dr
- Topic

Asking for help/ opinions

Content

ever since i watched one of the counselors at my camp play tron , i ' ve wanted to build it . the only problem is , i can ' t figure out which colors to build around . the group at my lgs that plays mainly modern is saying i should build r / g because it ' s the best , but i think the money that i would spend on a playset of [[grove of the burnwillows]] could be spent elsewhere and have a much bigger impact on the deck and the games i play with it . **so my question to you guys is what non-r / g variants of tron could be viable in a competitive modern environment ?**

tl;dr

what non-r / g variant should i build ? 

Vulgarism, Offensive words

Content

my little brother is a sophomore in high-school and he was having a bit of trouble with his crush not liking him so me being the brother i am gave him the advice " dude girls at this age should not be a factor for your happiness just focus on doing you for now " whereas i thought it was good advice he took it the completely other way and has become a huge [asshole](#) .

tl;dr

gave brother advice about life and now he is an asshole to women



True summary of the content

Content

not me but my **grandfather** was asked if he wanted to come in on an idea with 2 other guys . all he would need was 50 bucks and a little business experience but he said no . today that business is **hardee ' s** . he lost out big time .

tl;dr

grandfather had chance to invest in early hardee ' s , but declined .

Topic is important

Topic

Ultimate travel kit

Content

doing some traveling this year and i am looking to build the **ultimate travel kit** . . .
so far i have a bonavita 0.5l travel kettle and aeropress . looking for a grinder that
would maybe fit into the aeropress . this way i can stack them in each other and
have a compact travel kit .

Ultimate travel kit : what grinder would you recommend that fits in aeropress ?

↑
topic

↑
tl;dr

Sub-datasets across verticals

Sub-dataset	Number of (content, summary) pairs
Questions	78,710
Vulgar Posts	299,145
True Summaries	966,430
Topic + tl;dr	729,042
Topic	729,042

Deep Learning for Summarization

Why Deep Learning ?

Why Deep Learning ?

- Data is not always linearly separable

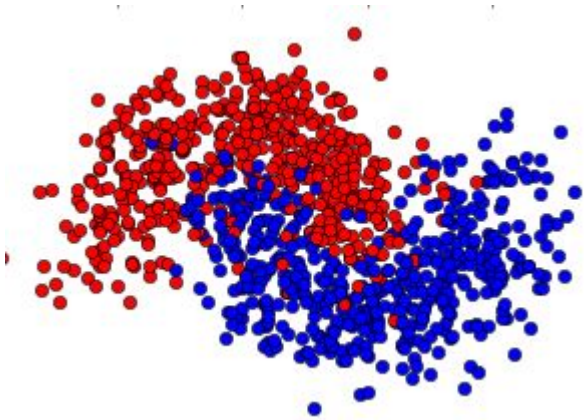

Why Deep Learning ?

- Data is not always linearly separable

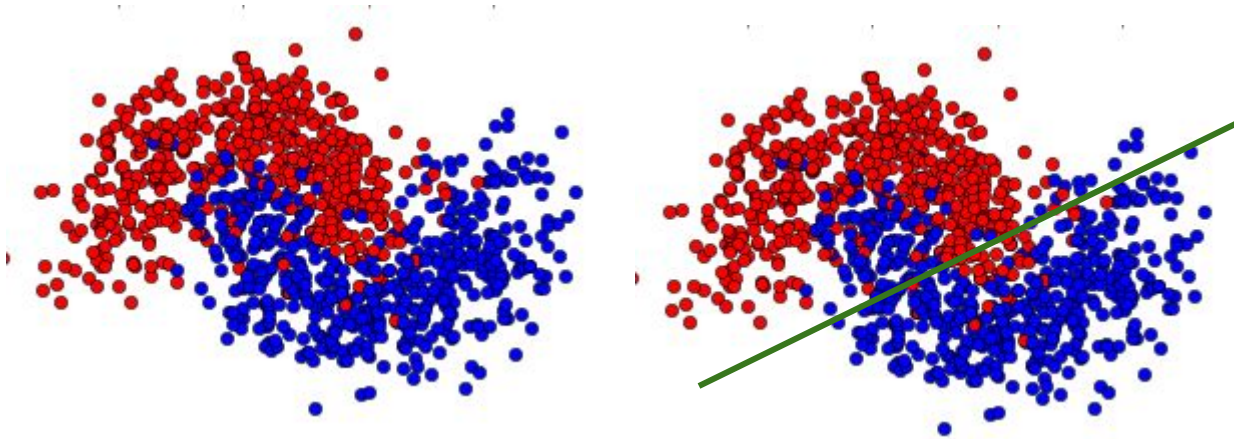

Why Deep Learning ?

- Deep learning models provide **non-linearity**

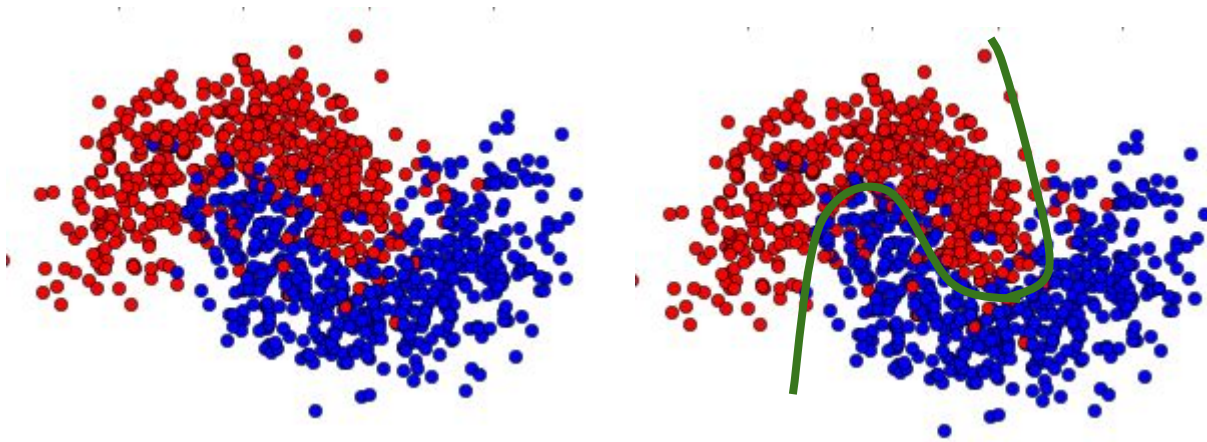

Why Deep Learning ?

- **Approximate** a function around the datapoints (**Learning**)

Why Deep Learning ?

- **Approximate** a function around the datapoints (**Learning**)
- Chaining & stacking non-linear units into layers helps the model learn complex relationships (**Deep**)

Why Deep Learning ?

- **Approximate** a function around the datapoints (**Learning**)
- Chaining & stacking non-linear units into layers helps the model learn complex relationships (**Deep**)
- Different type of data requires different architecture

Recurrent Neural Network

What is a RNN ?

What is a RNN ?

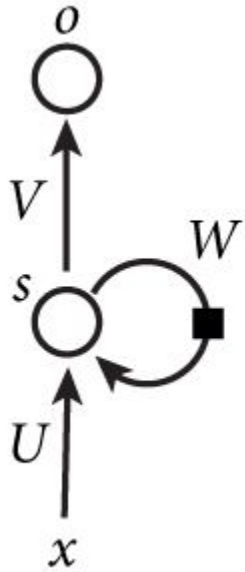

What is a RNN ?

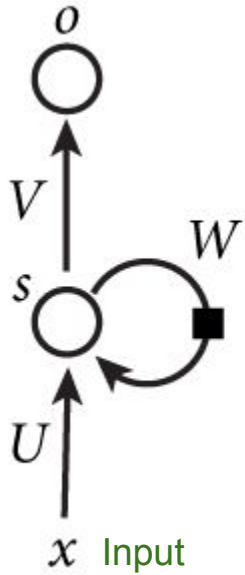

What is a RNN ?

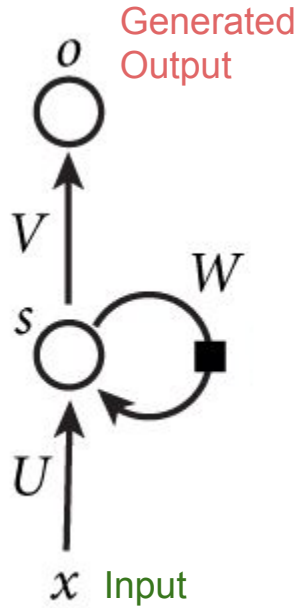

What is a RNN ?

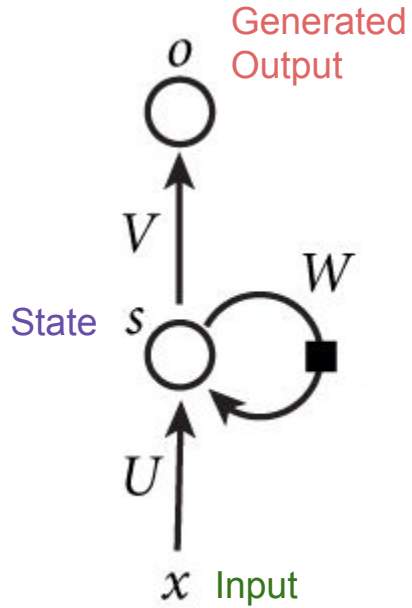

What is a RNN ?

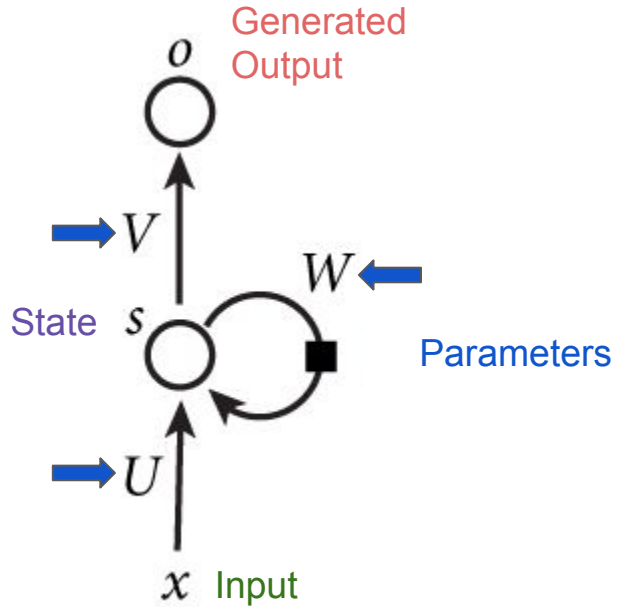

What is a RNN ?

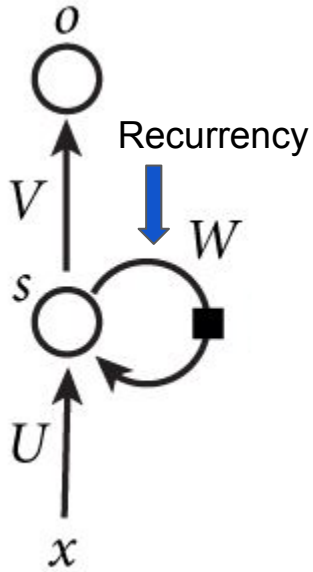

What is a RNN ?

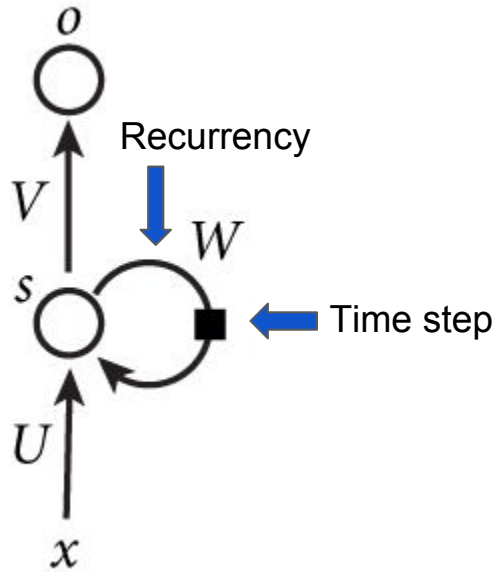

What is a RNN ?

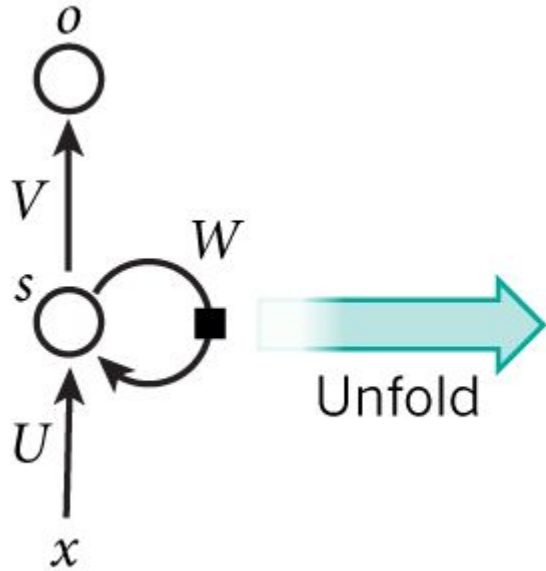

What is a RNN ?

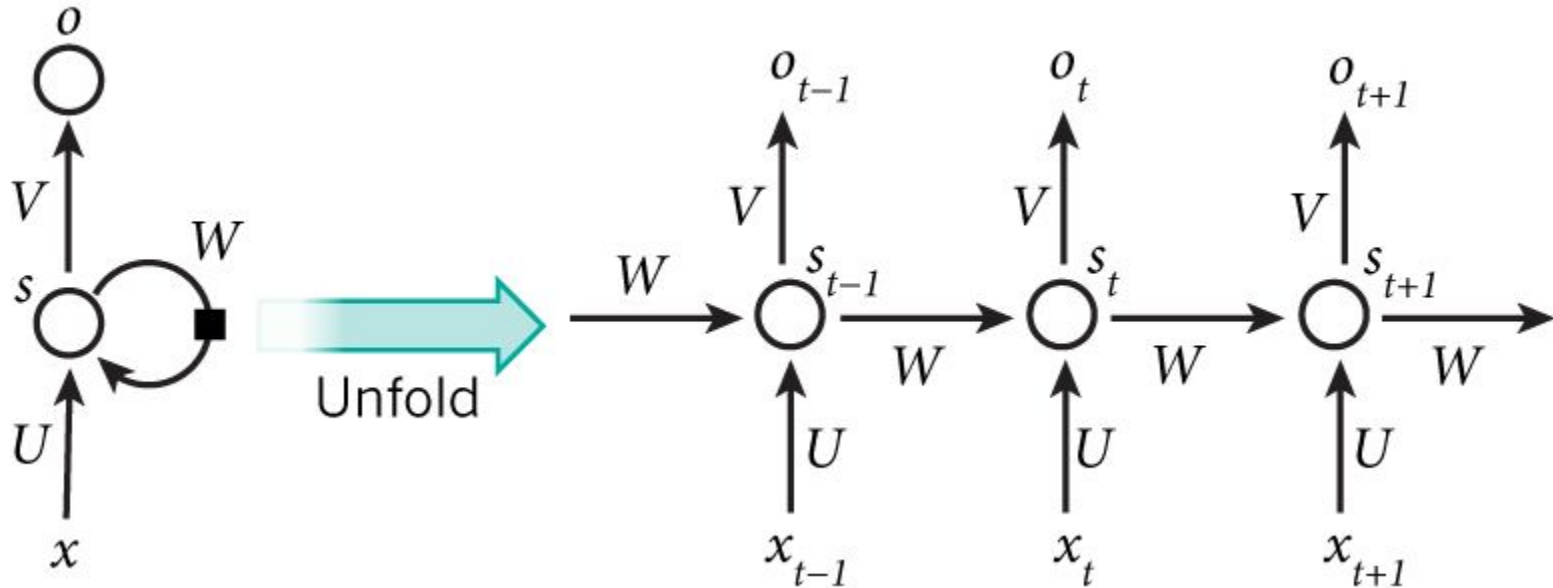

What happens in a RNN ?

What happens in a RNN ?

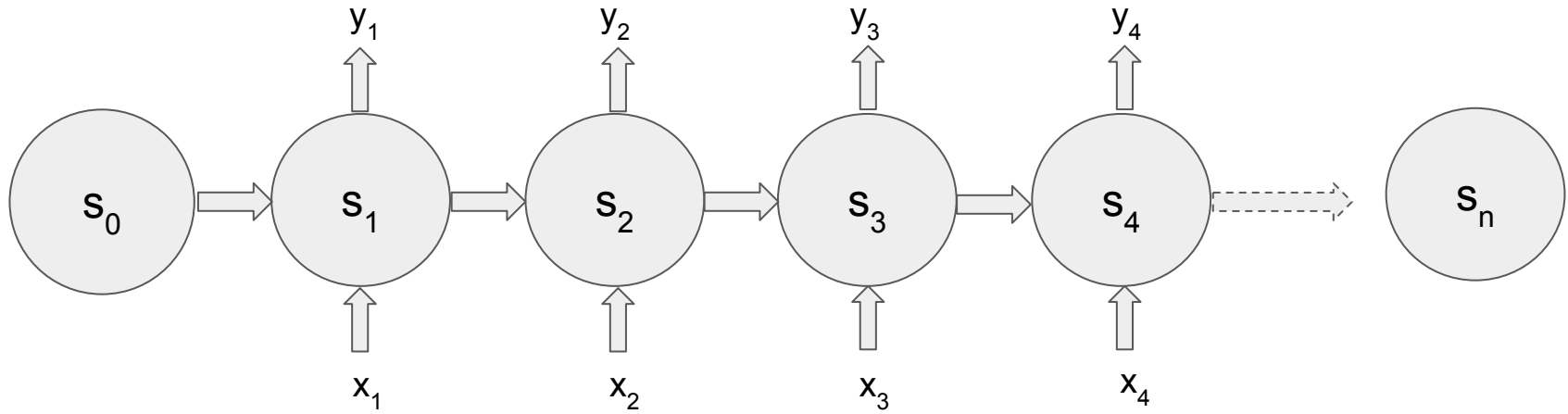

What happens in a RNN ?

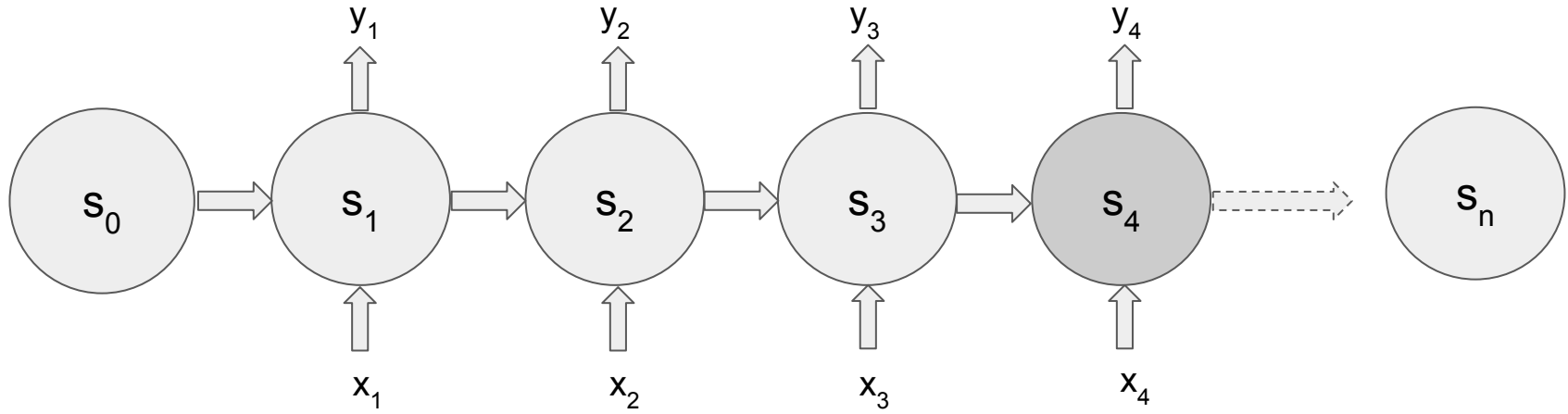

What happens in a RNN ?

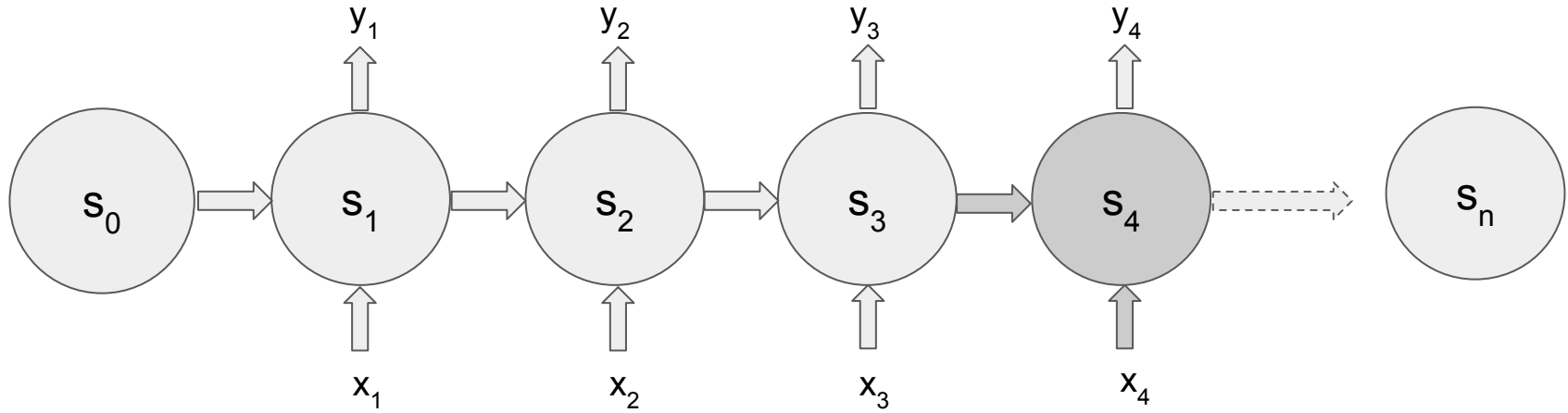

$$s_4 = f(s_3, x_4)$$

What happens in a RNN ?

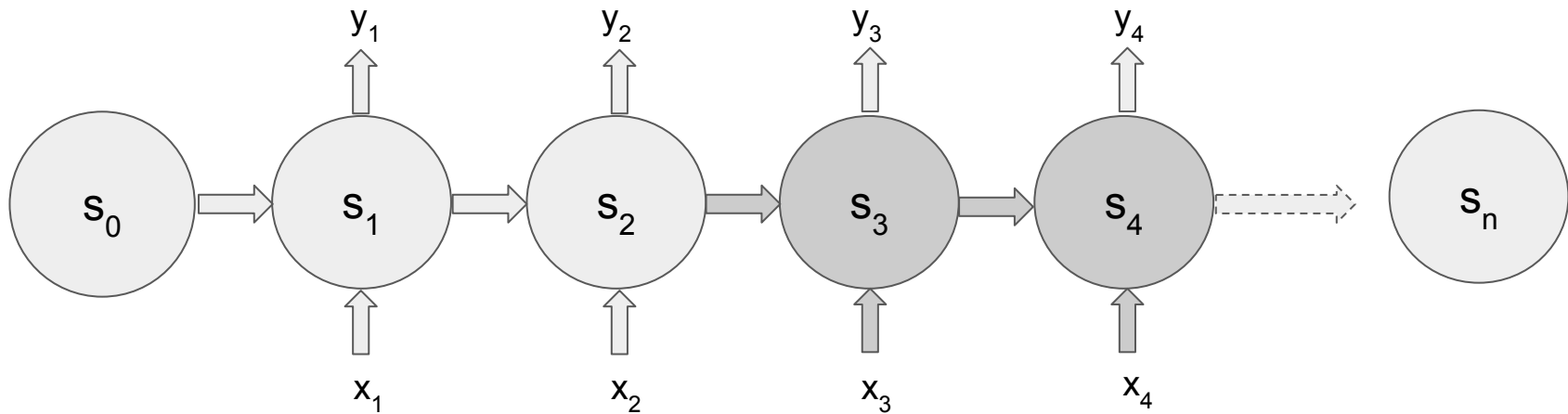

$$\begin{aligned} s_4 &= f(s_3, x_4) \\ &\Downarrow \\ &= f(f(s_2, x_3), x_4) \end{aligned}$$

What happens in a RNN ?

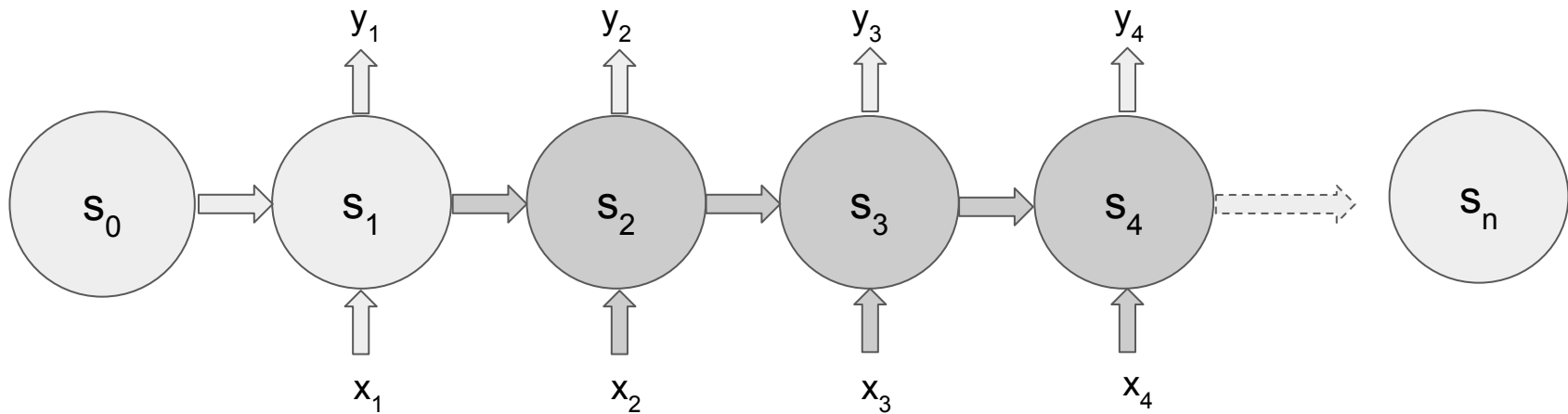

$$\begin{aligned} s_4 &= f(s_3, x_4) \\ &\Downarrow \\ &= f(f(s_2, x_3), x_4) \\ &\Downarrow \\ &= f(f(f(s_1, x_2), x_3), x_4) \end{aligned}$$

What happens in a RNN ?

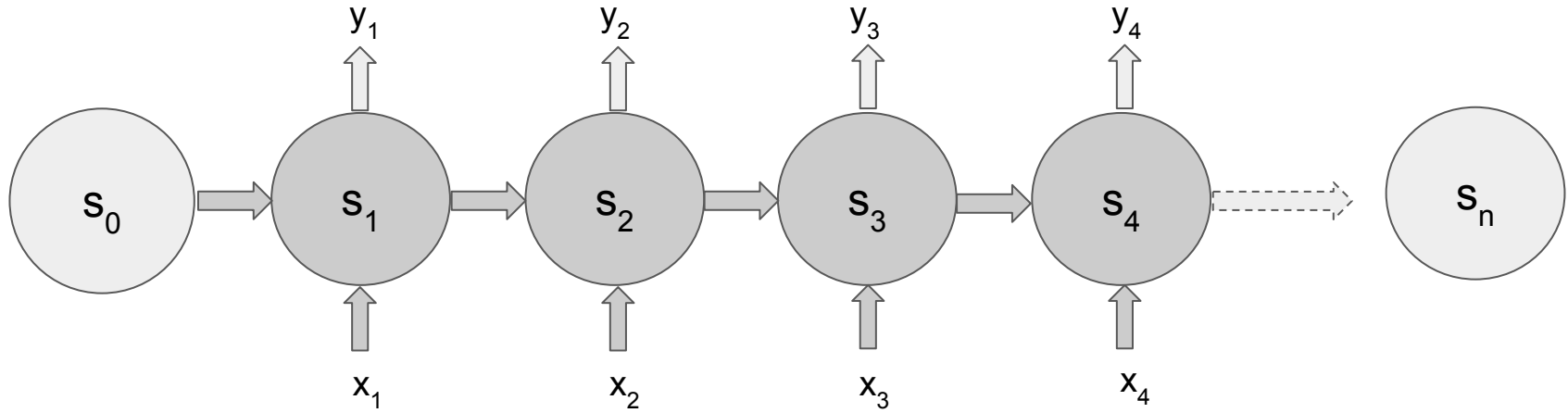

$$\begin{aligned} s_4 &= f(s_3, x_4) \\ &\Downarrow \\ &= f(f(s_2, x_3), x_4) \\ &\Downarrow \\ &= f(f(f(s_1, x_2), x_3), x_4) \\ &\Downarrow \\ &= f(f(f(f(s_0, x_1), x_2), x_3), x_4) \end{aligned}$$

What happens in a state?

What happens in a state?

word_1

What happens in a state?

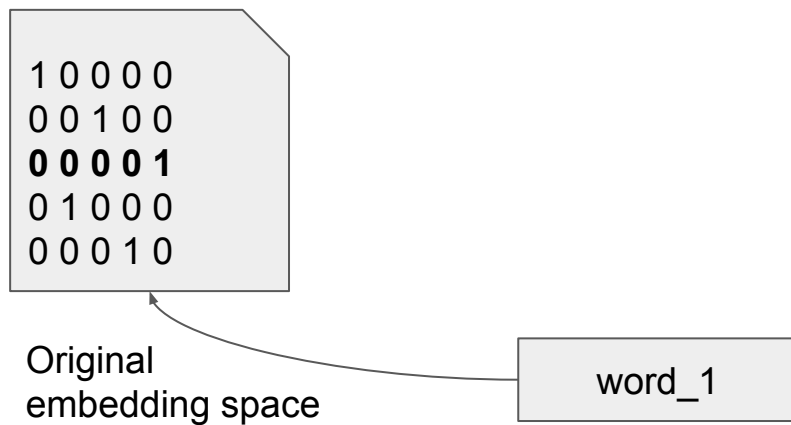

What happens in a state?

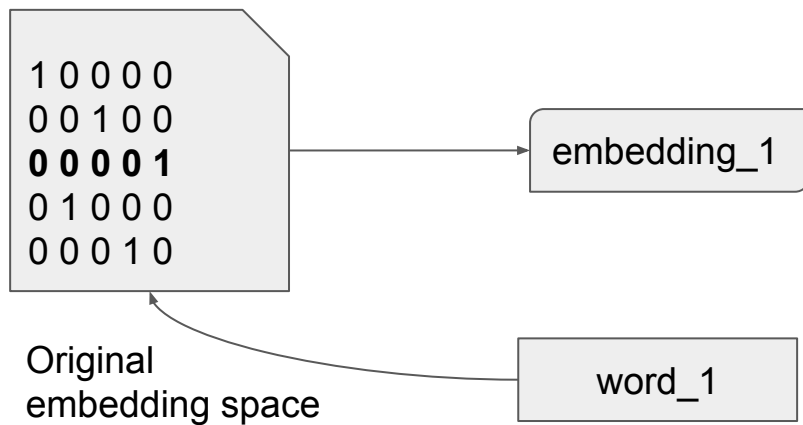

What happens in a state?

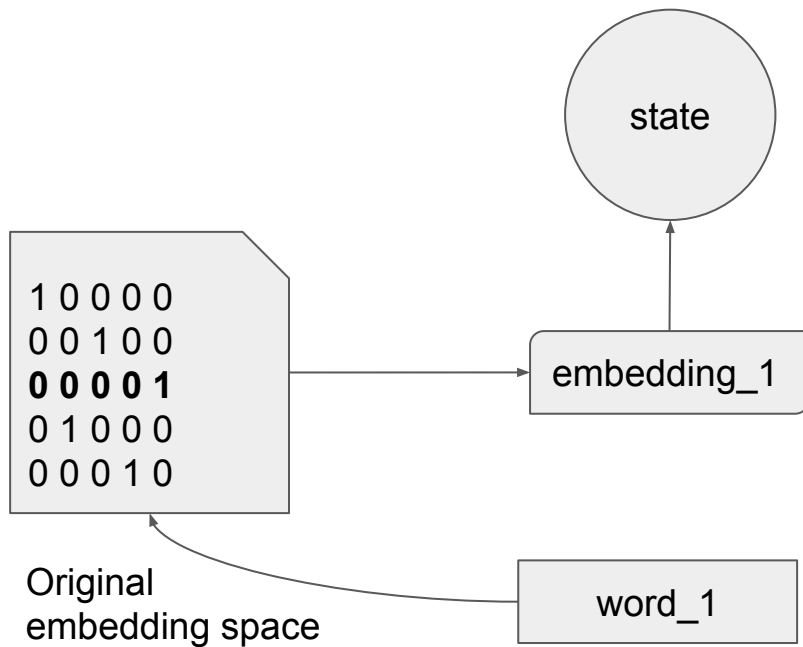

What happens in a state?

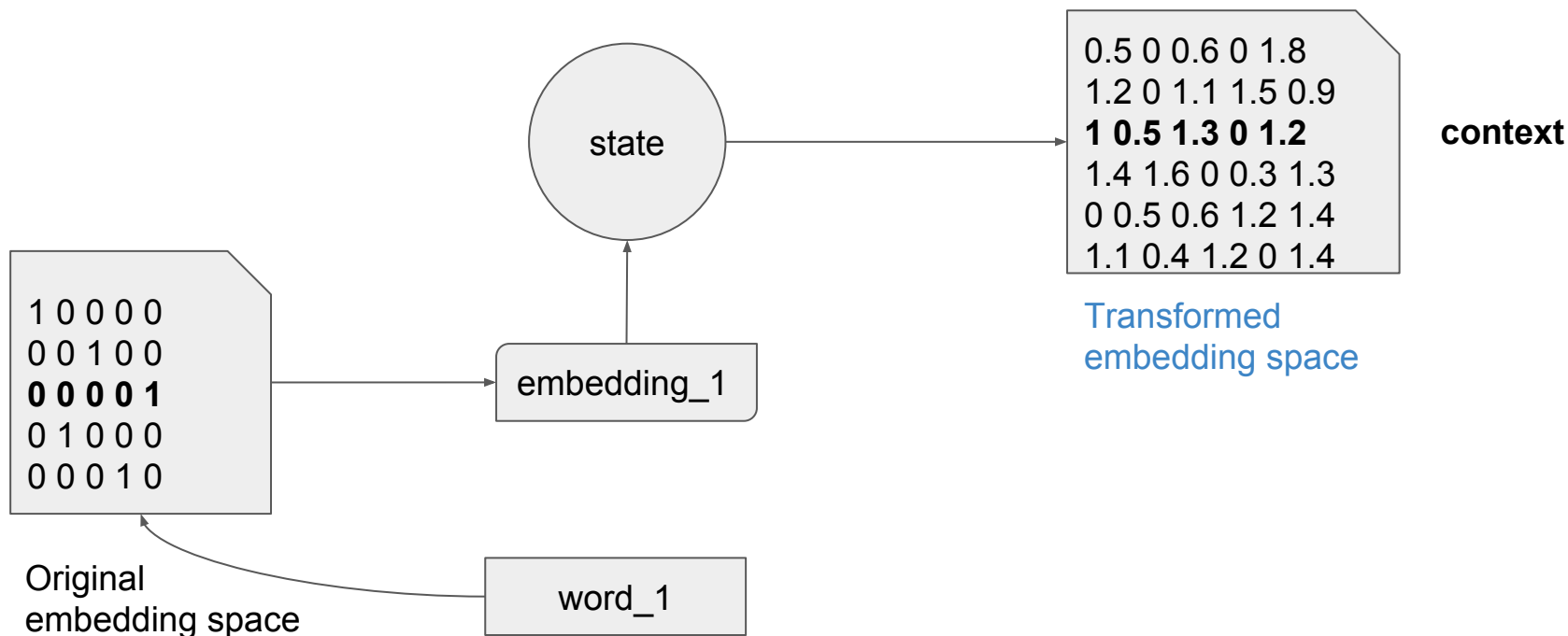

Sequence to Sequence model

Sequence to Sequence model

Sind Sie noch wach?  Are you still awake?

Learning to map a sequence to sequence

Learning to map a sequence to sequence

Source sequence (P)

$$X = \{x_1, x_2, x_3, x_4, \dots, x_n\}$$

Learning to map a sequence to sequence

Source sequence (P)

$$X = \{x_1, x_2, x_3, x_4, \dots, x_n\}$$

Target sequence (Q)

$$Y = \{y_1, y_2, y_3, y_4, \dots, y_m\}$$

Learning to map a sequence to sequence

Source sequence (P)

$$X = \{x_1, x_2, x_3, x_4, \dots, x_n\}$$

Target sequence (Q)

$$Y = \{y_1, y_2, y_3, y_4, \dots, y_m\}$$



**Minimize the negative
likelihood**



Learning to map a sequence to sequence

Source sequence (P)

$$X = \{x_1, x_2, x_3, x_4, \dots, x_n\}$$

Target sequence (Q)

$$Y = \{y_1, y_2, y_3, y_4, \dots, y_m\}$$



**Minimize the negative
likelihood**



Maximize

$p(Y|X, \text{parameters})$

Sequence to Sequence model

Sequence to Sequence model

S_word1 S_word2 S_word3 S_word4

Source sequence

Sequence to Sequence model

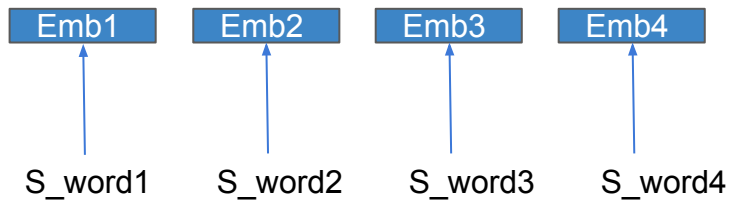

Source sequence

Sequence to Sequence model

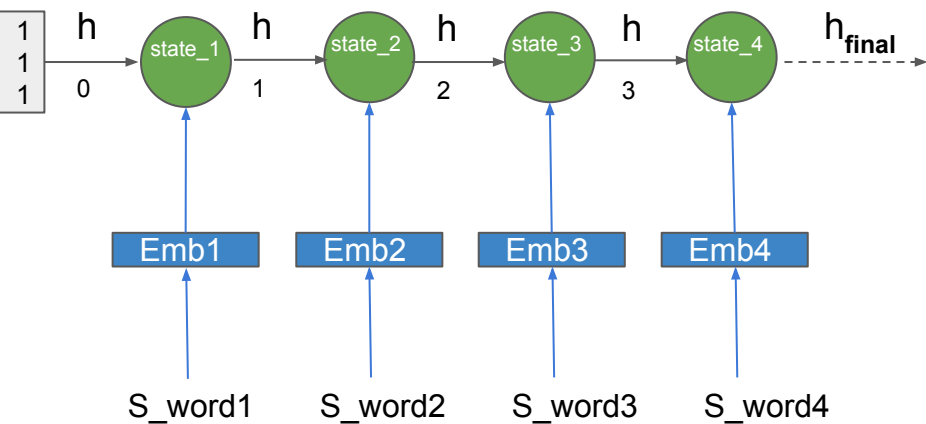

Source sequence

Sequence to Sequence model

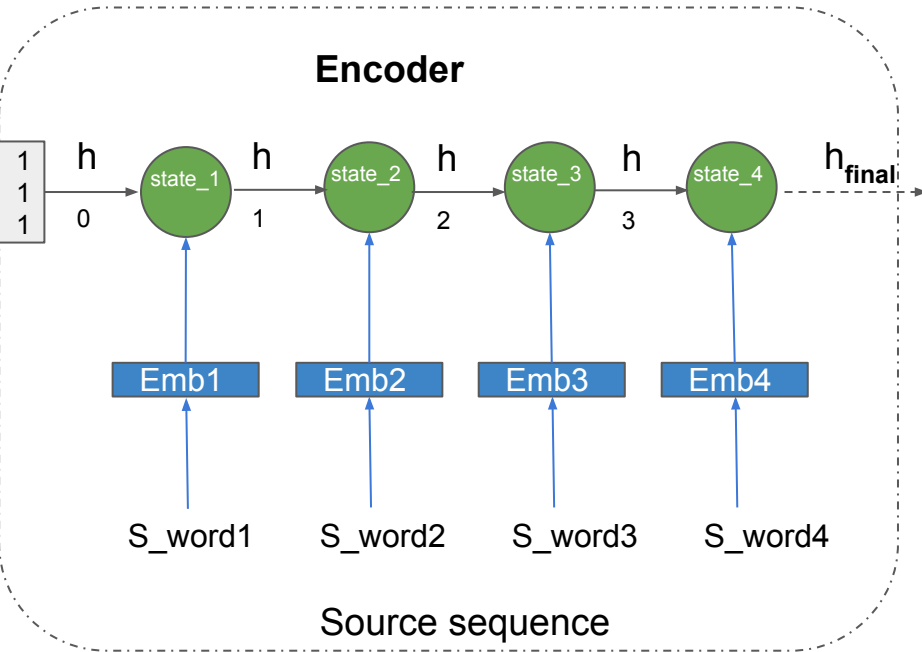

Sequence to Sequence model

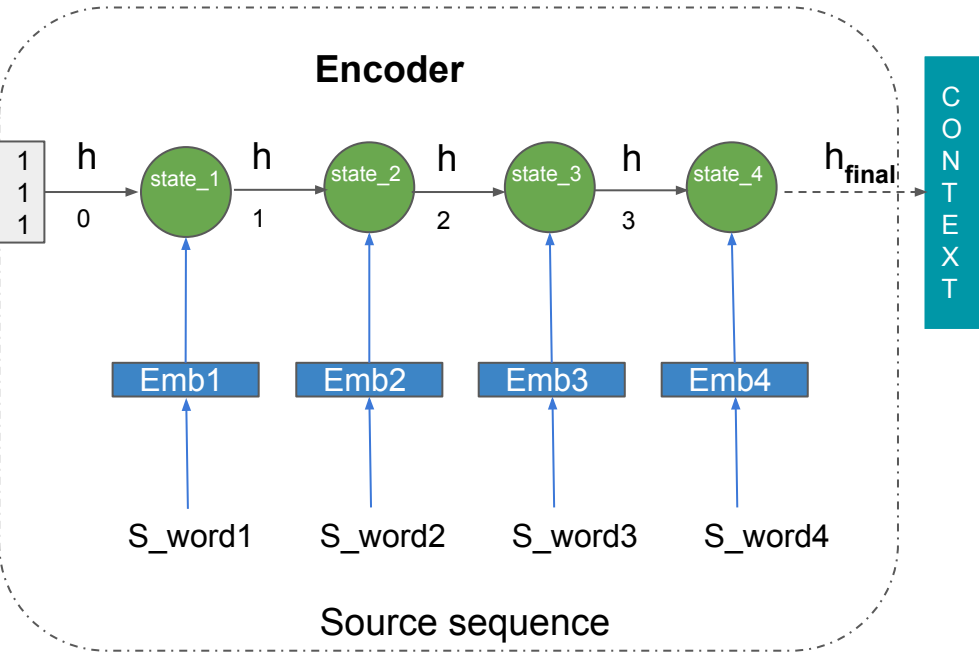

Sequence to Sequence model

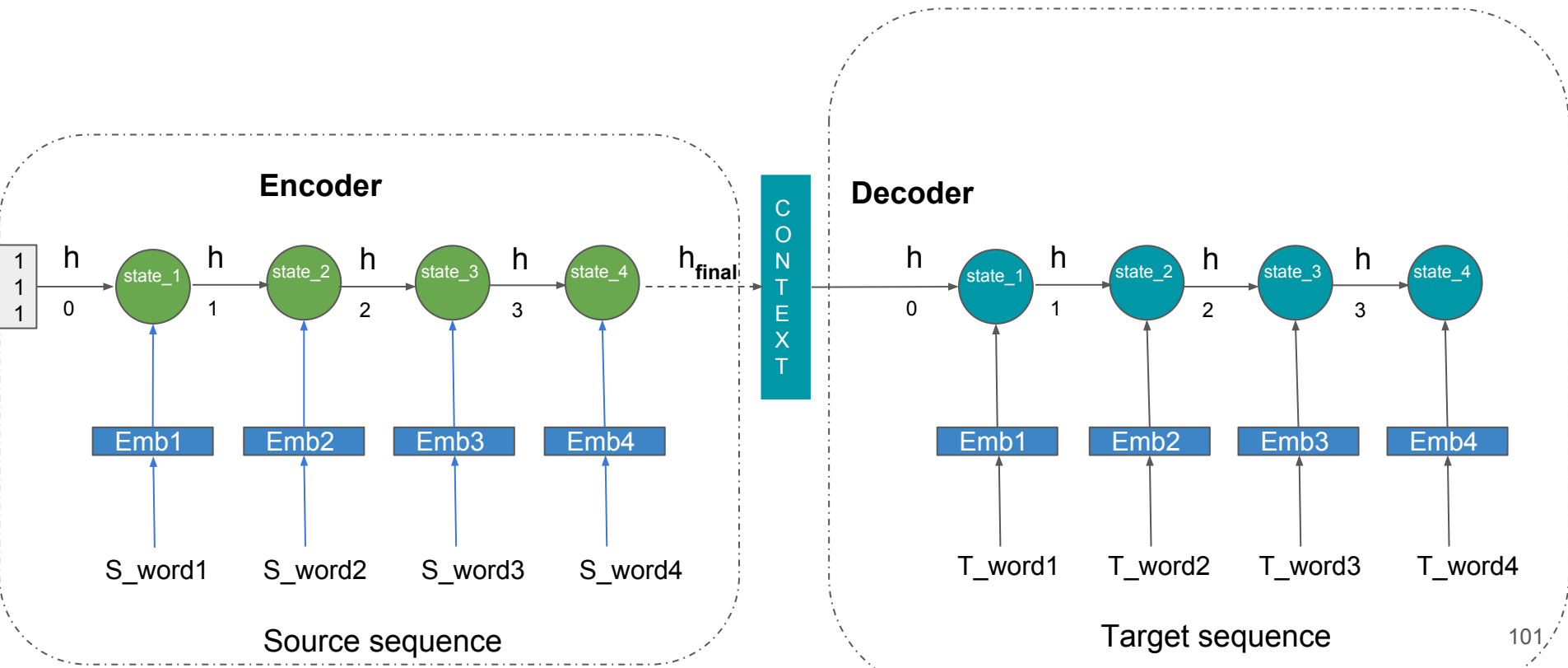

Sequence to Sequence model

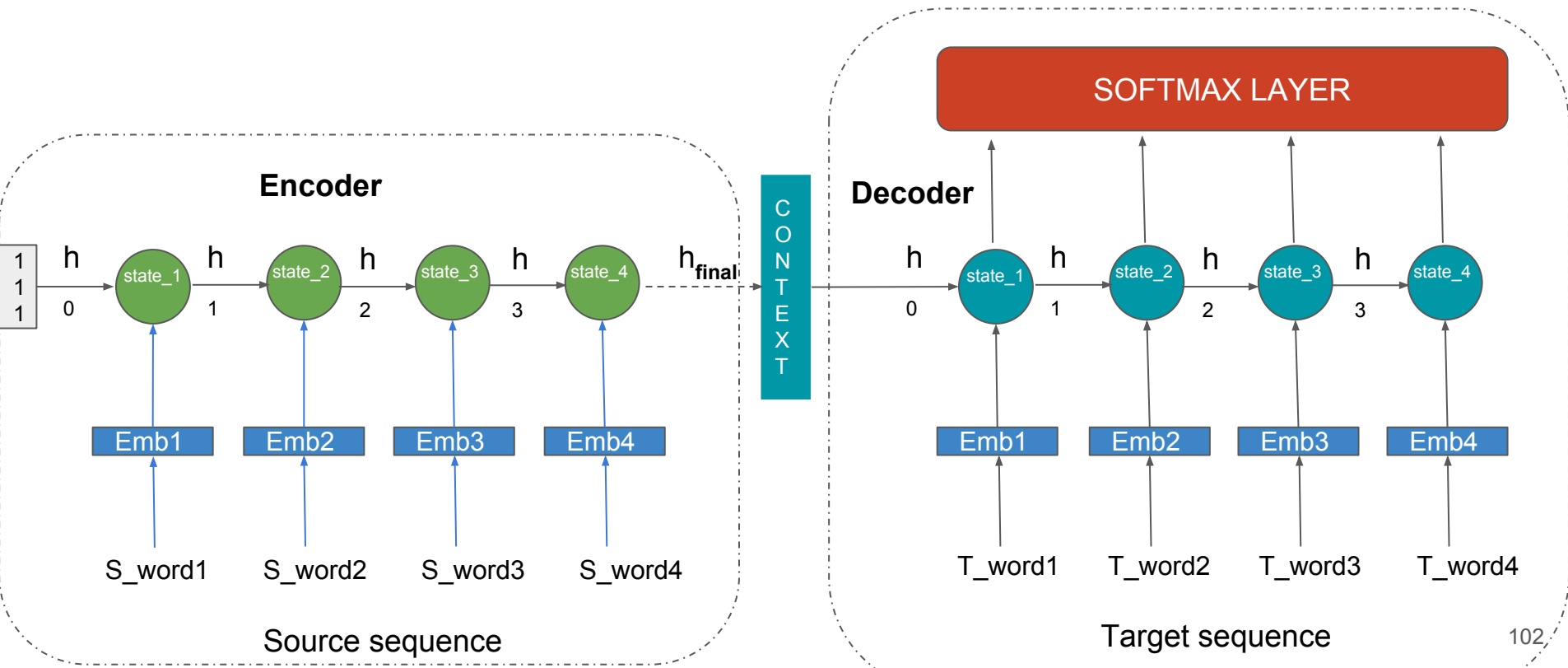

Sequence to Sequence model

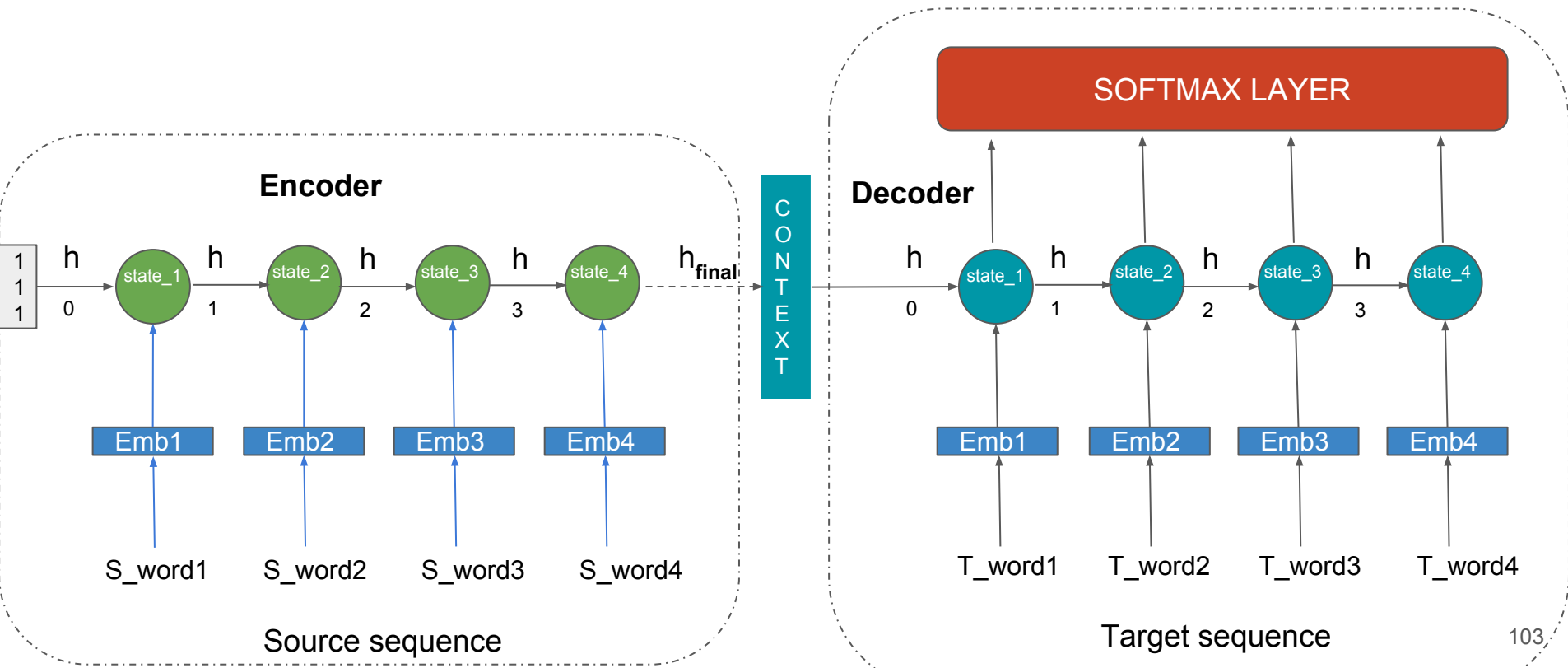

Sequence to Sequence model

this, target is, vocabulary the, containing, some, words,

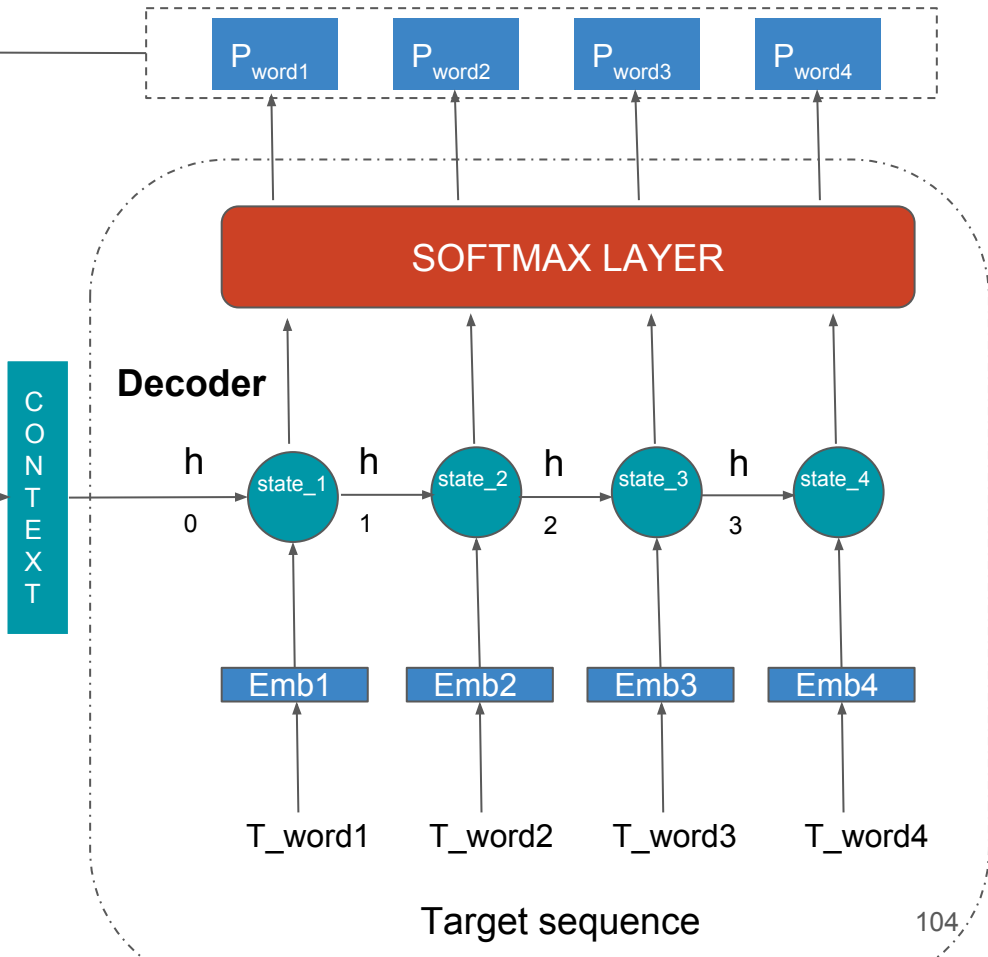
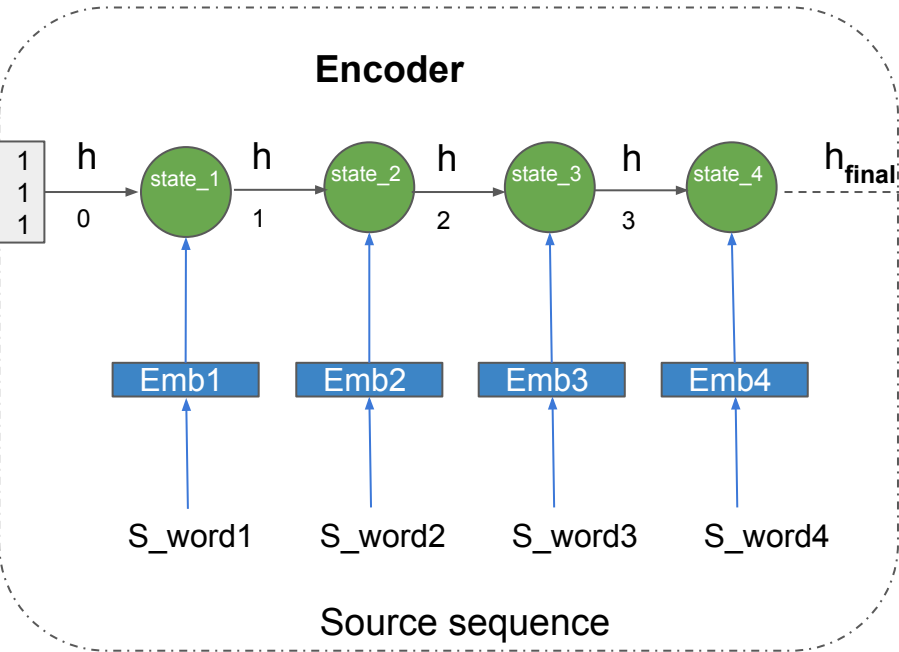

Sequence to Sequence model

Trained end to end

this, target is, vocabulary the, containing, some, words,

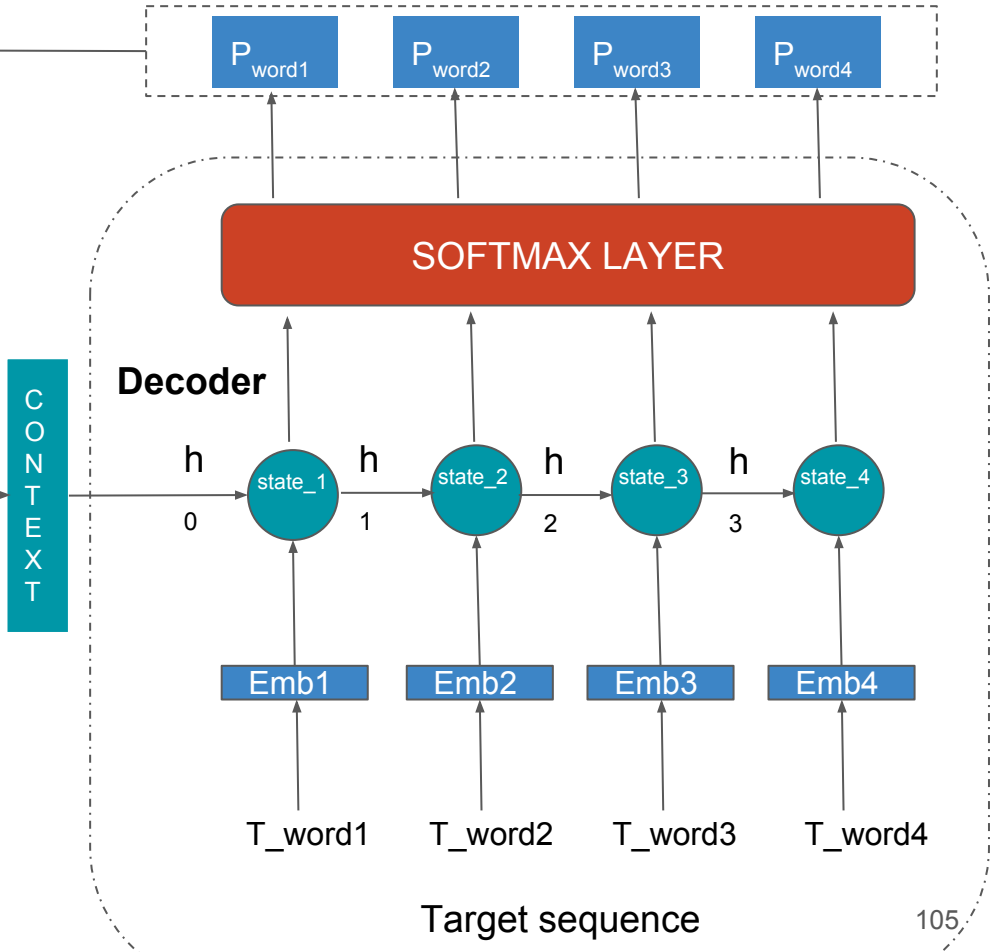
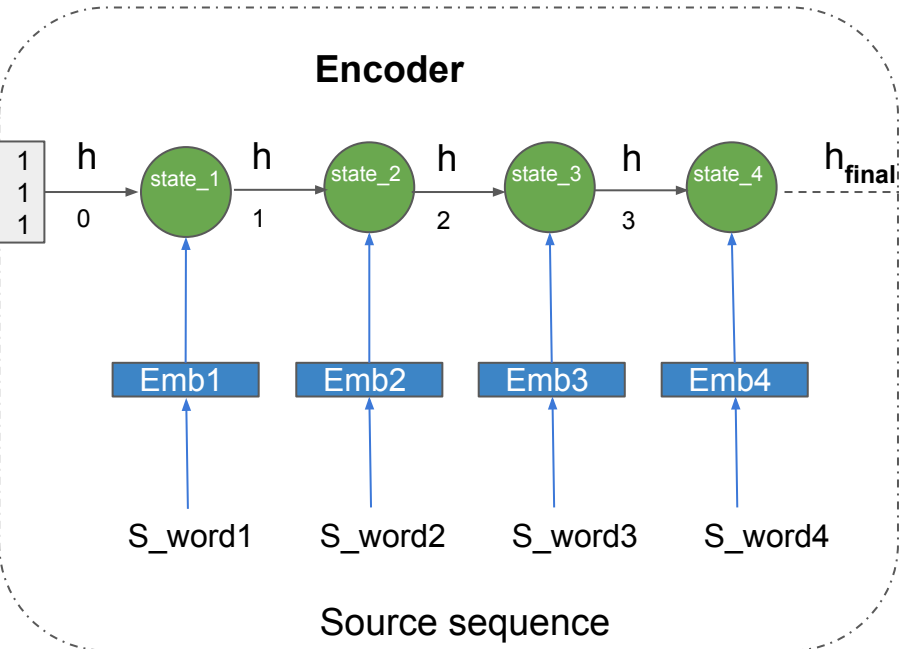

Sequence to Sequence model - Generating summary

this, target is, vocabulary the, containing, some, words,

Summary

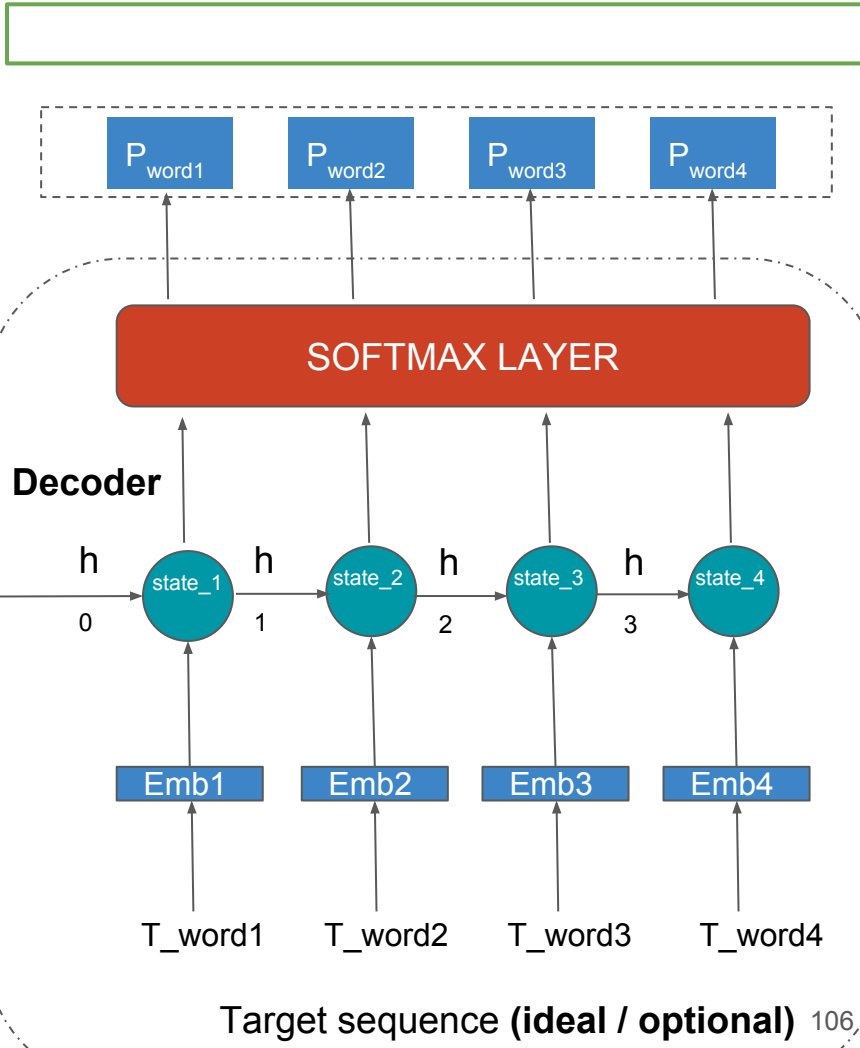
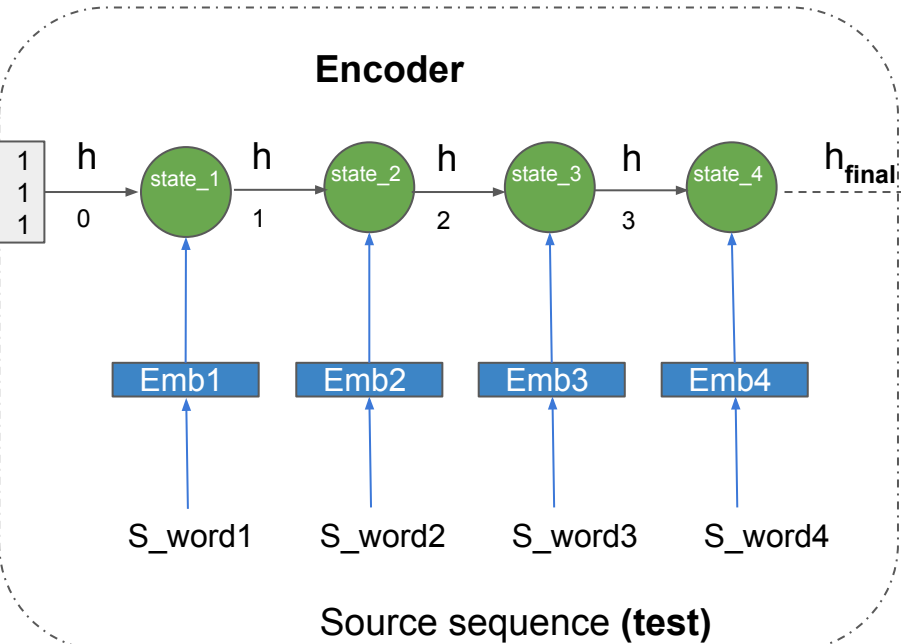

Sequence to Sequence model - Generating summary

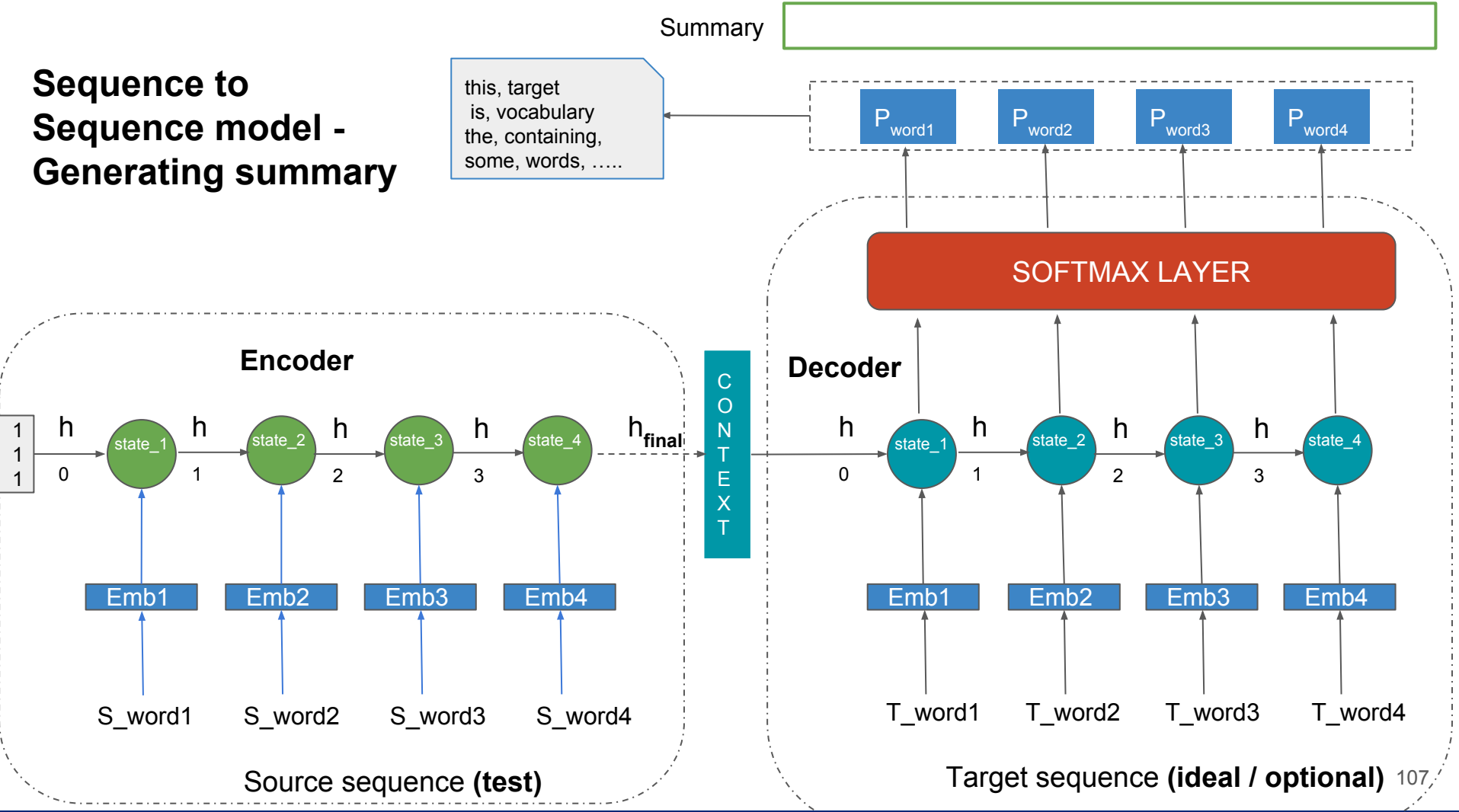

Sequence to Sequence model - Generating summary

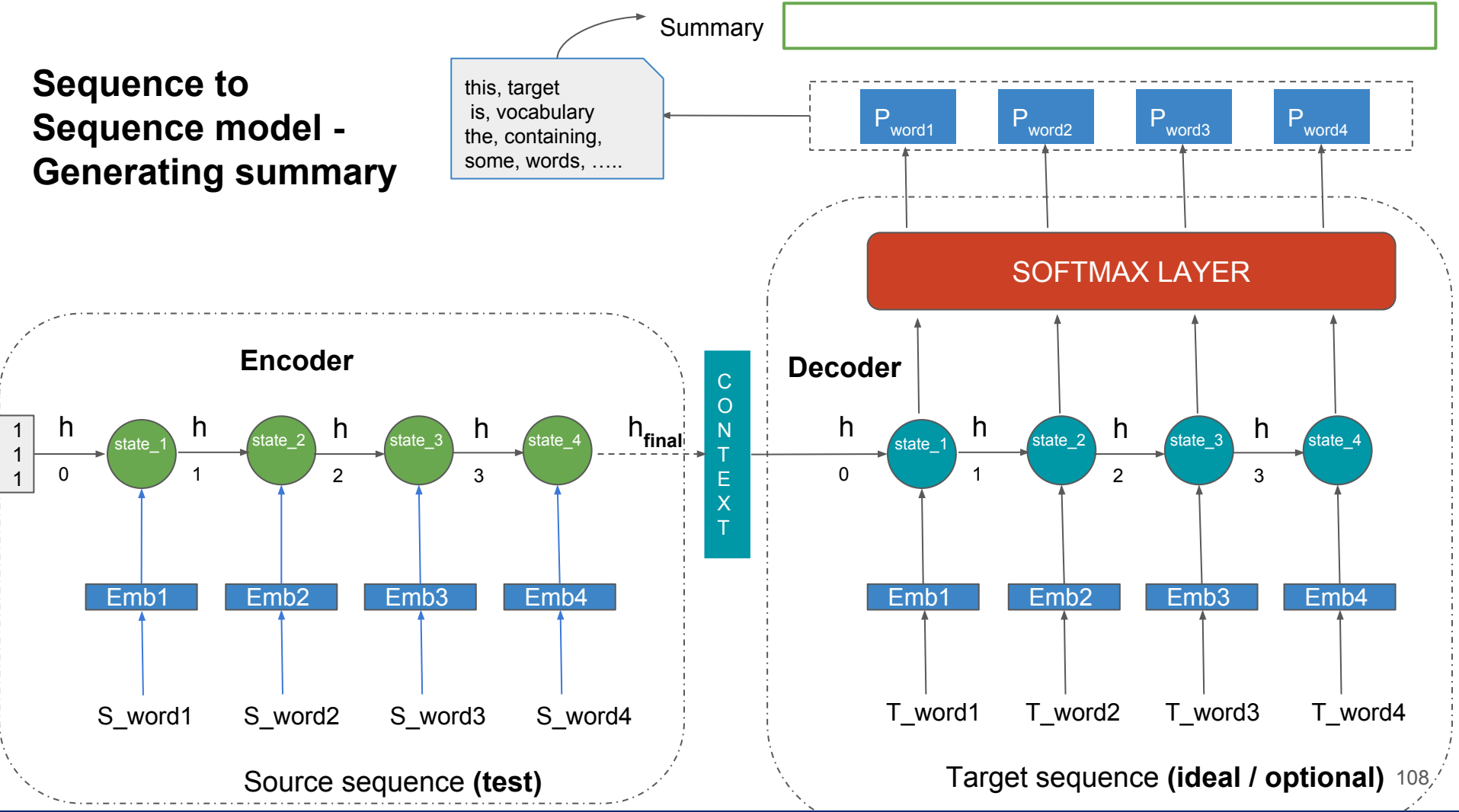

Sequence to Sequence model - Generating summary

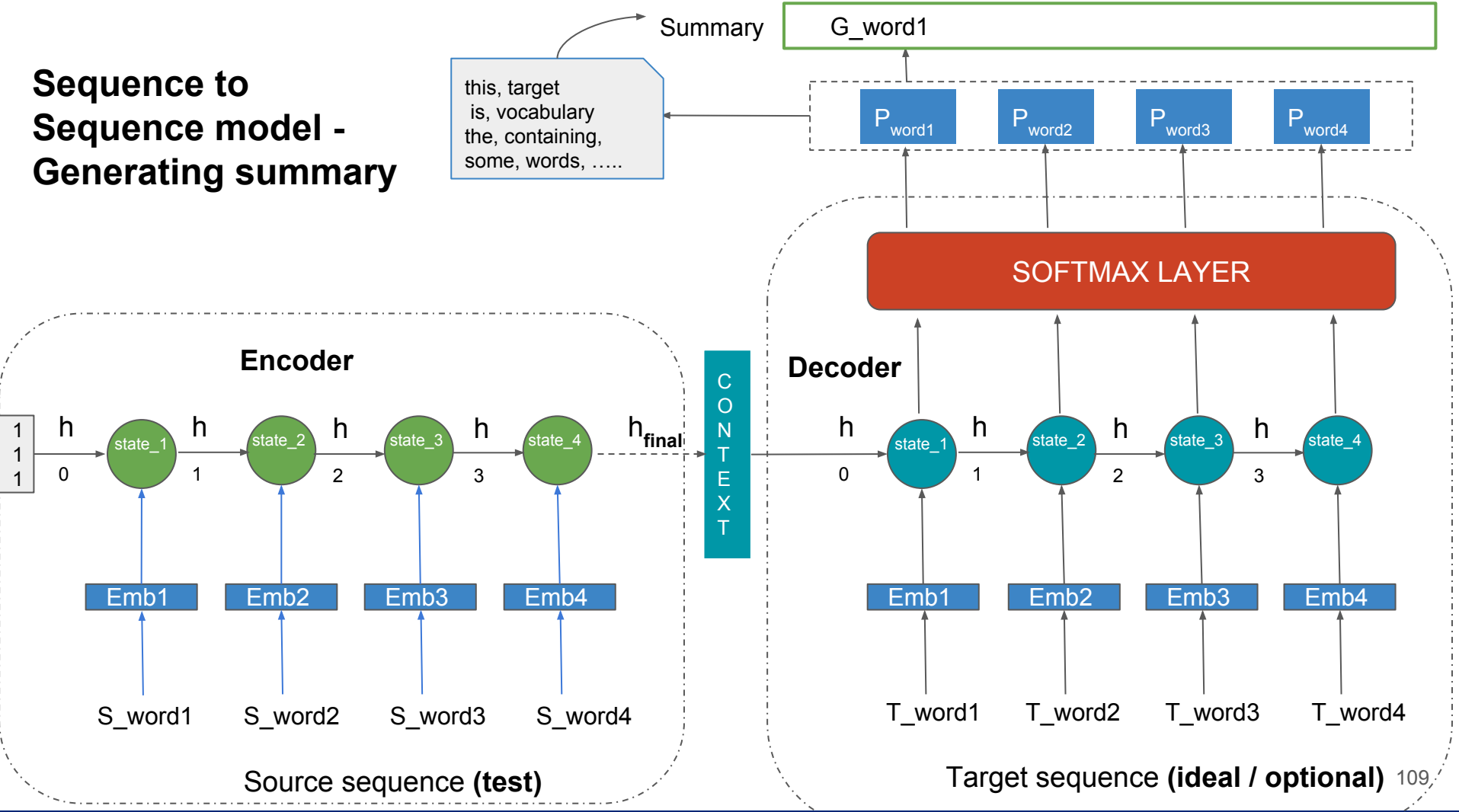

Sequence to Sequence model - Generating summary

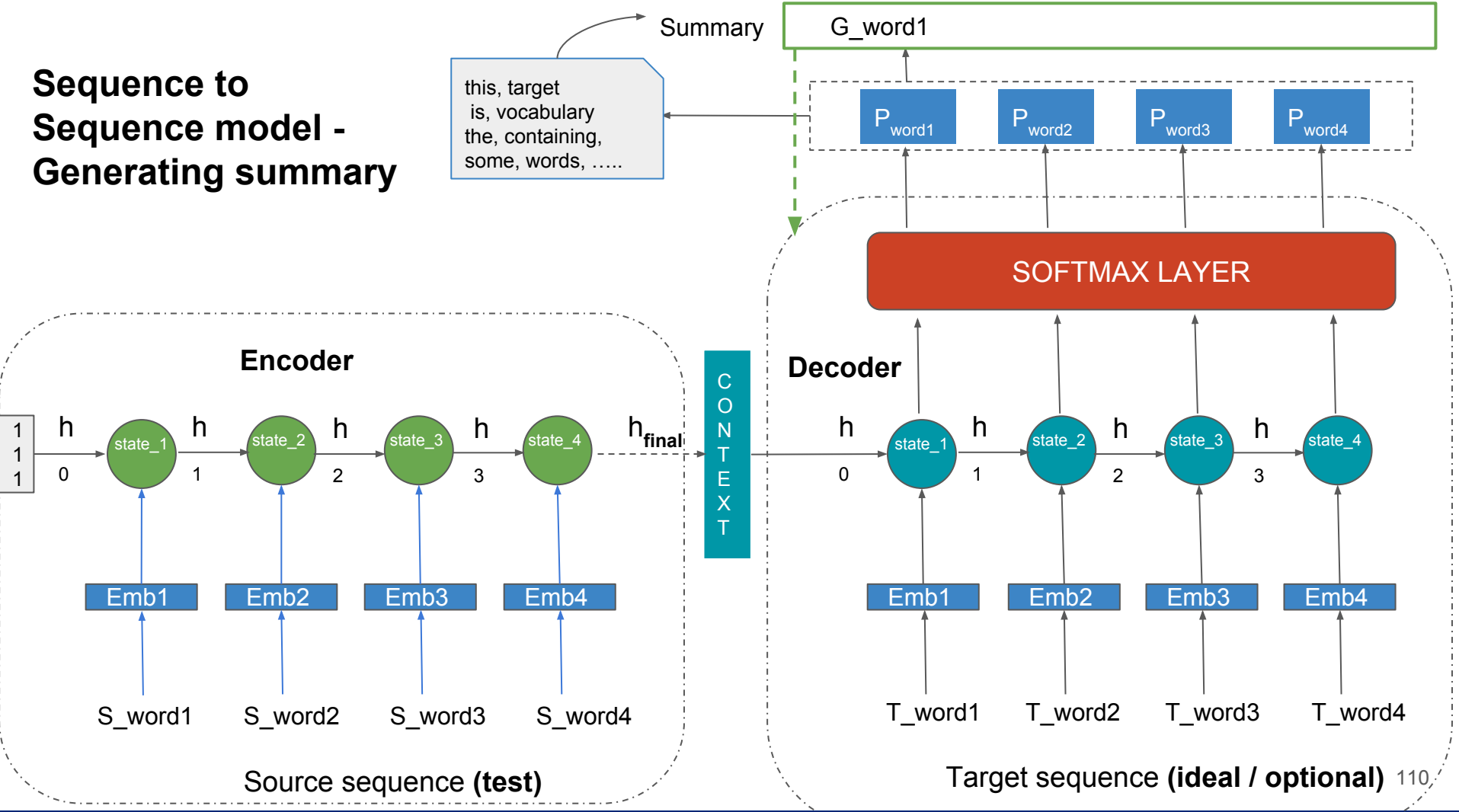

Sequence to Sequence model - Generating summary

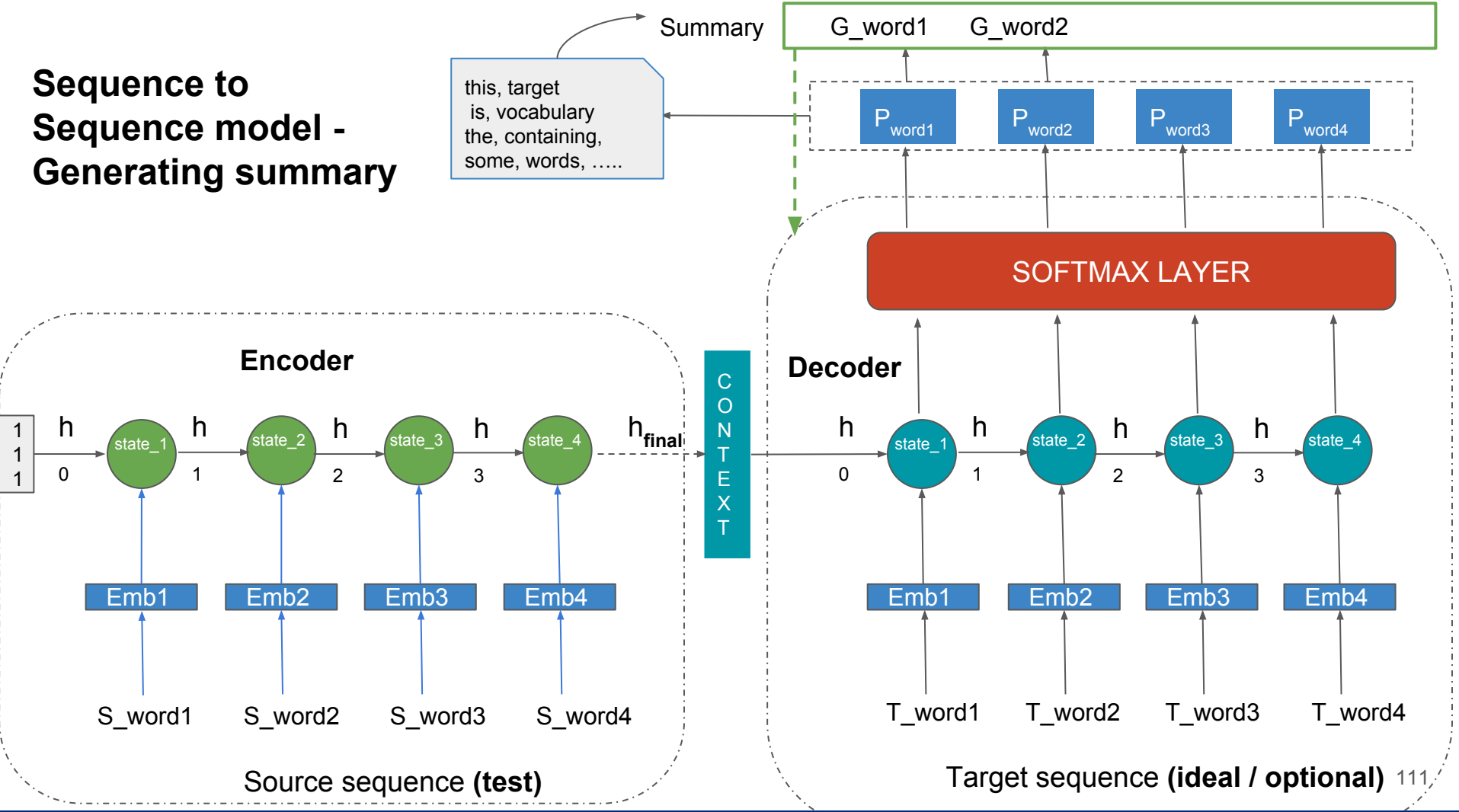

Sequence to Sequence model - Generating summary

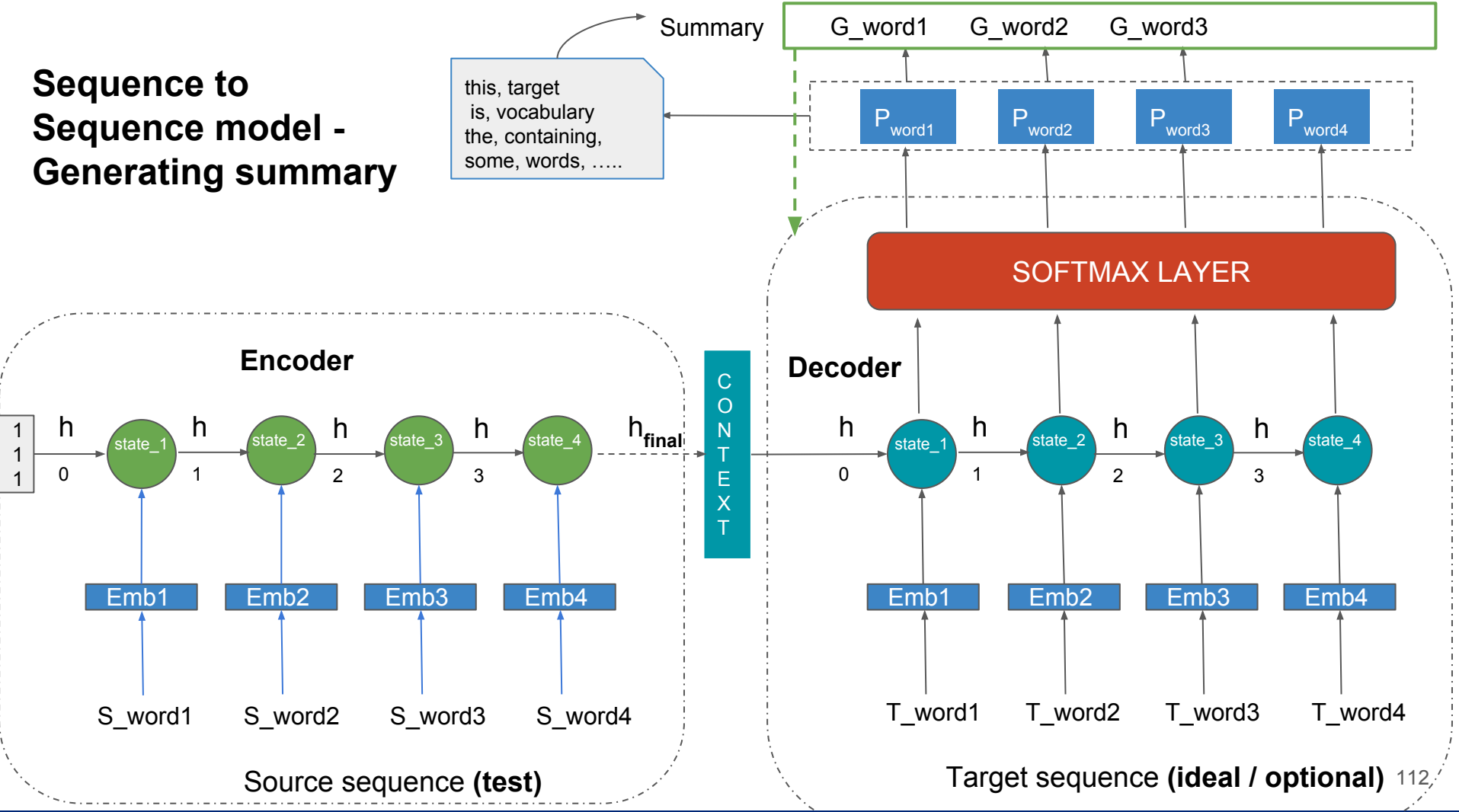

Sequence to Sequence model - Generating summary

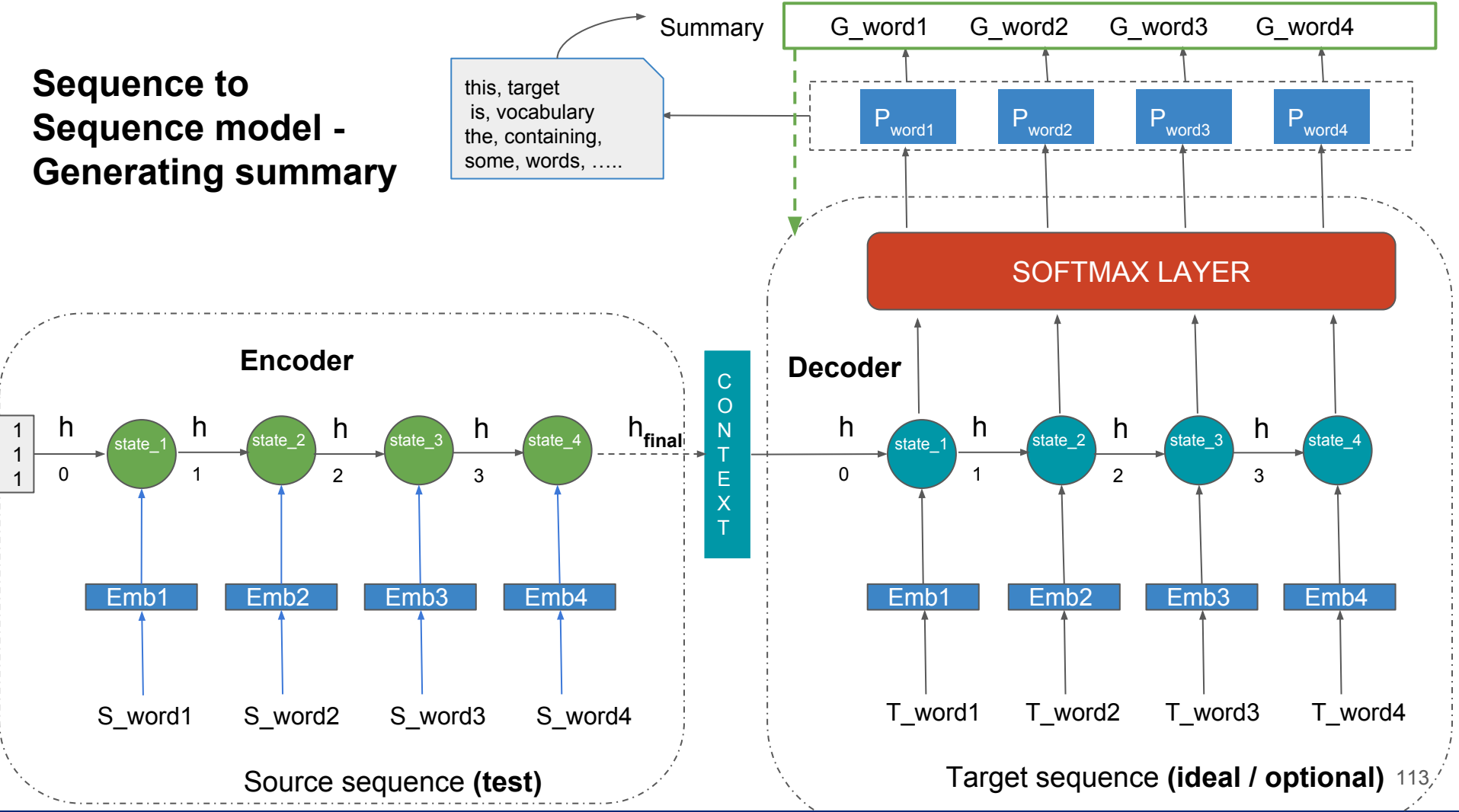

Attention!

Sequence to Sequence model

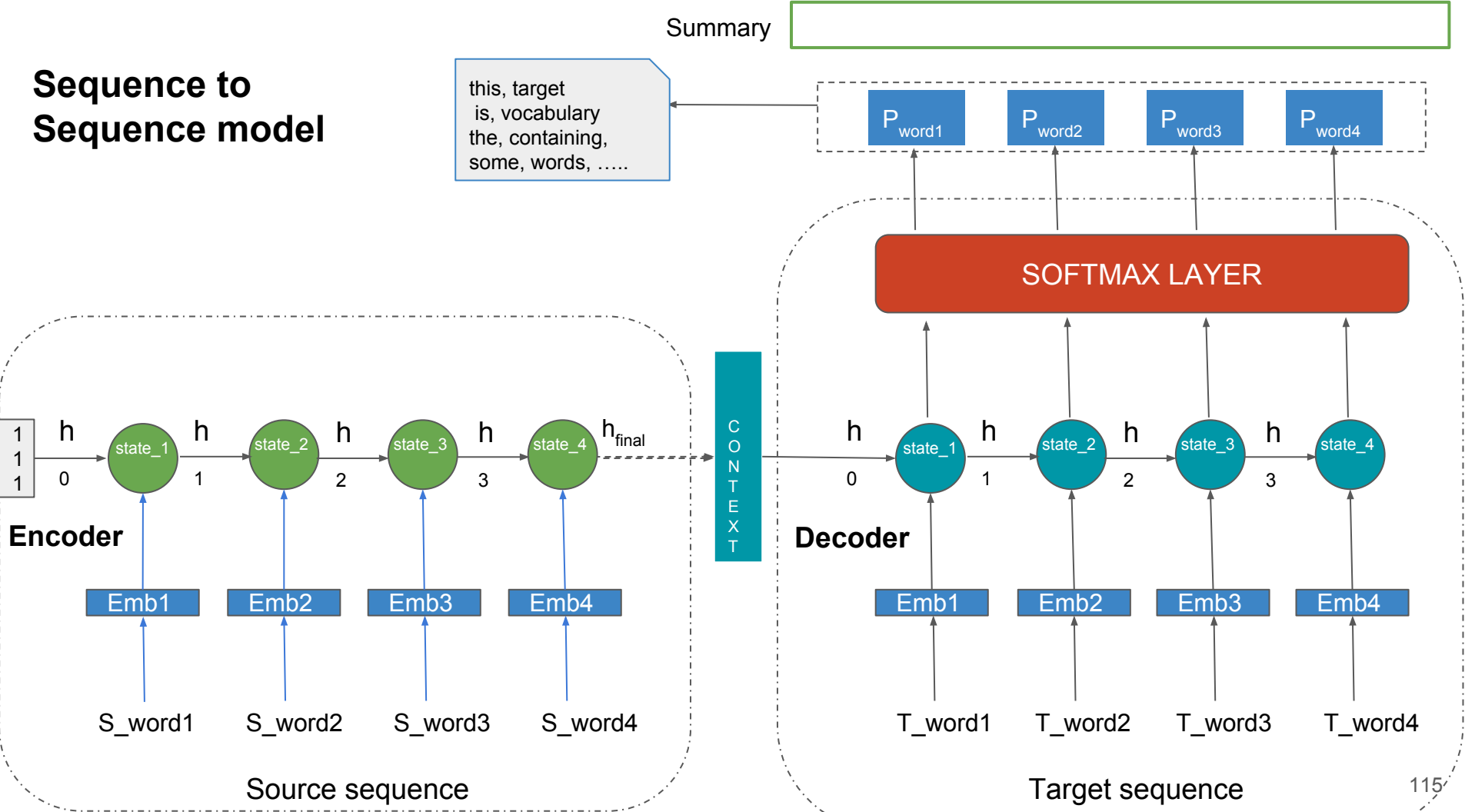

Sequence to Sequence model

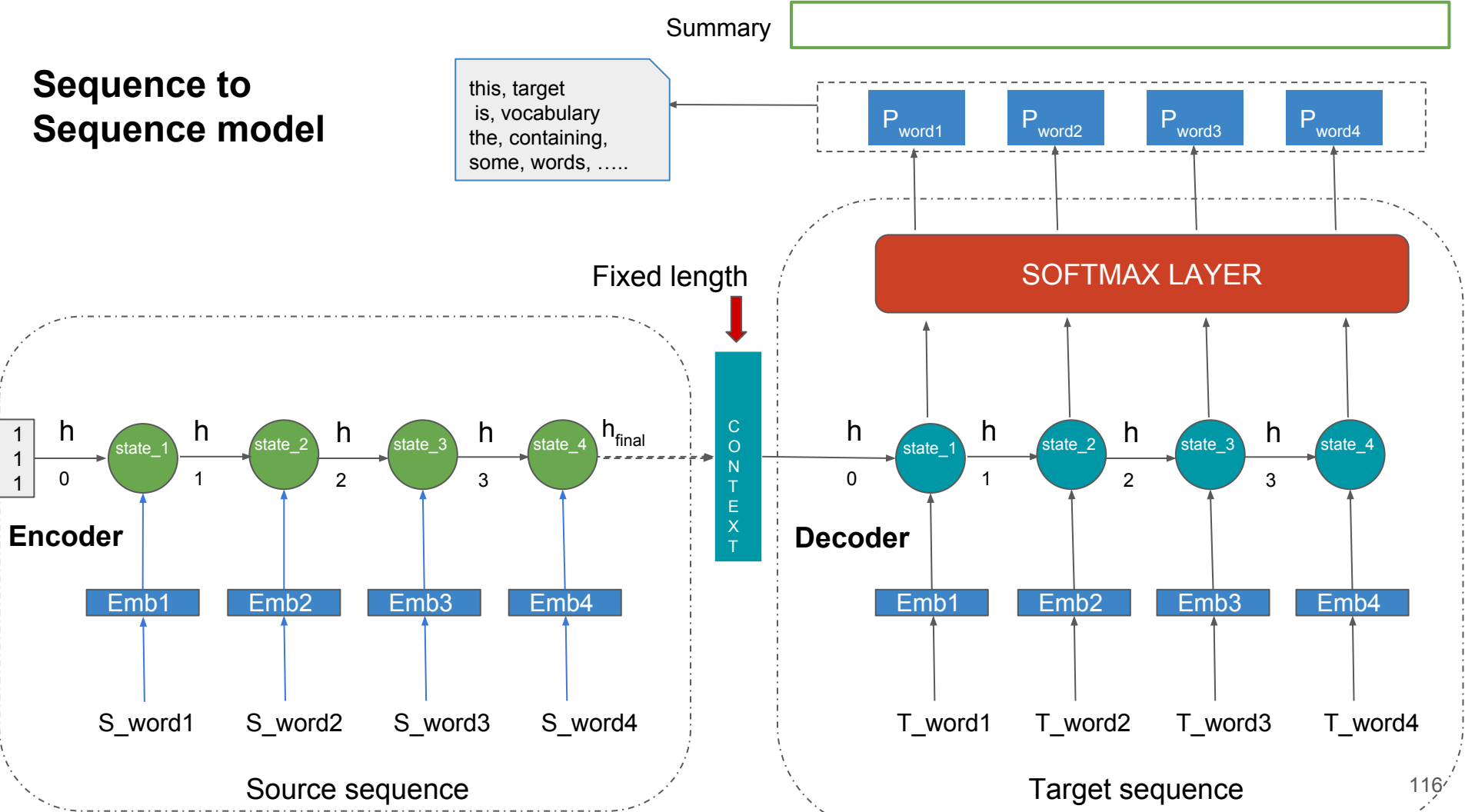

Sequence to Sequence model

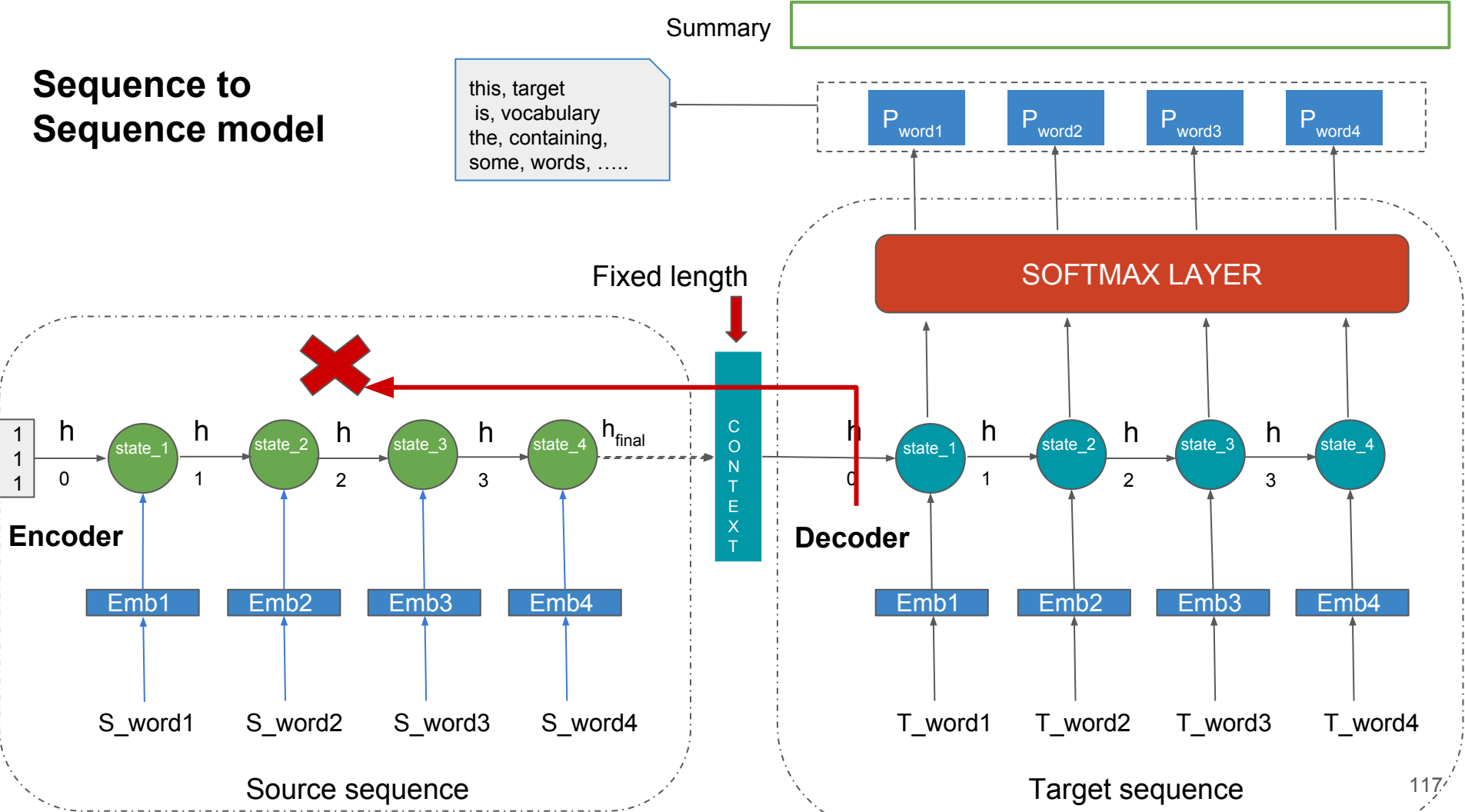

Sequence to Sequence model with attention

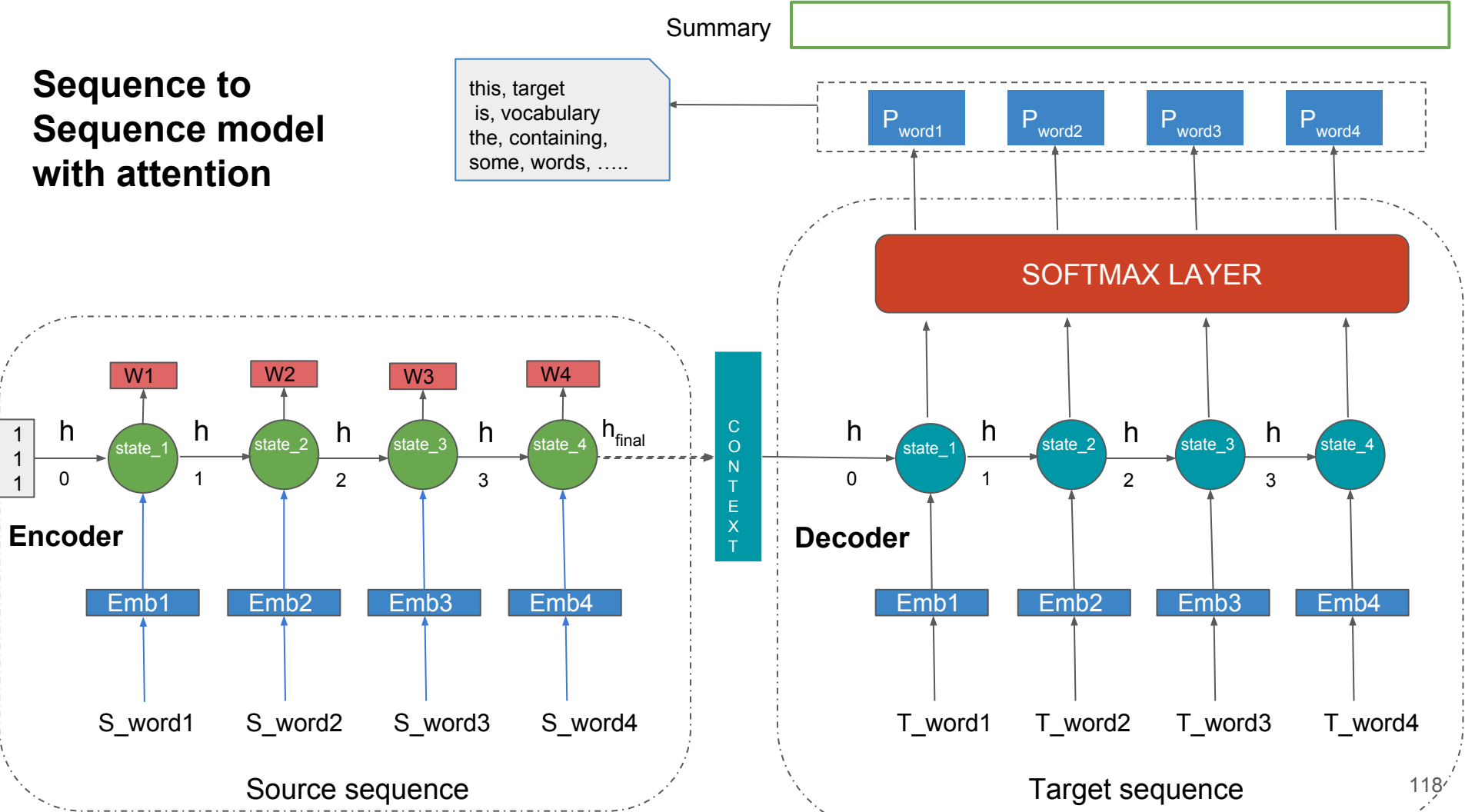

Sequence to Sequence model with attention

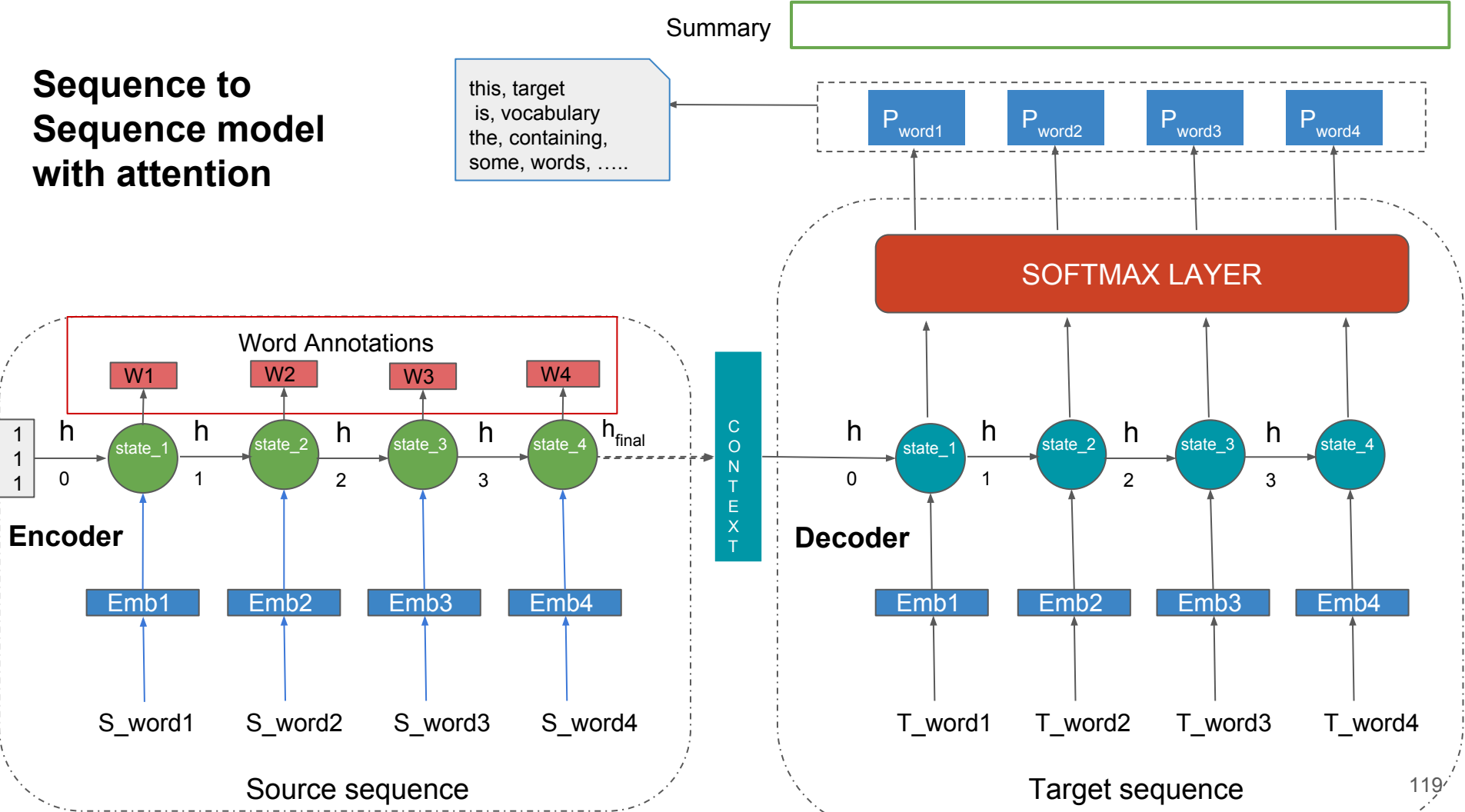

Sequence to Sequence model with attention

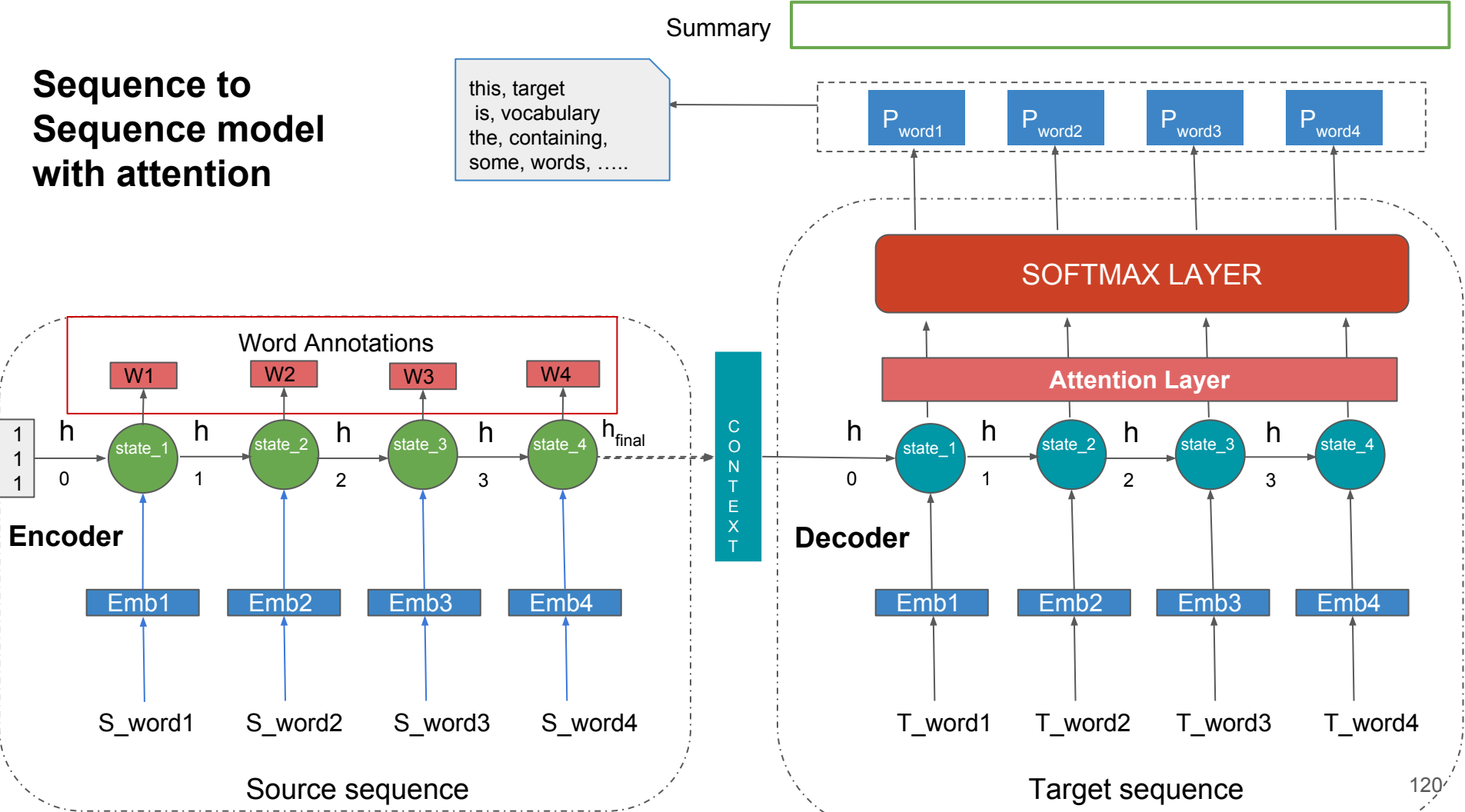

Sequence to Sequence model with attention

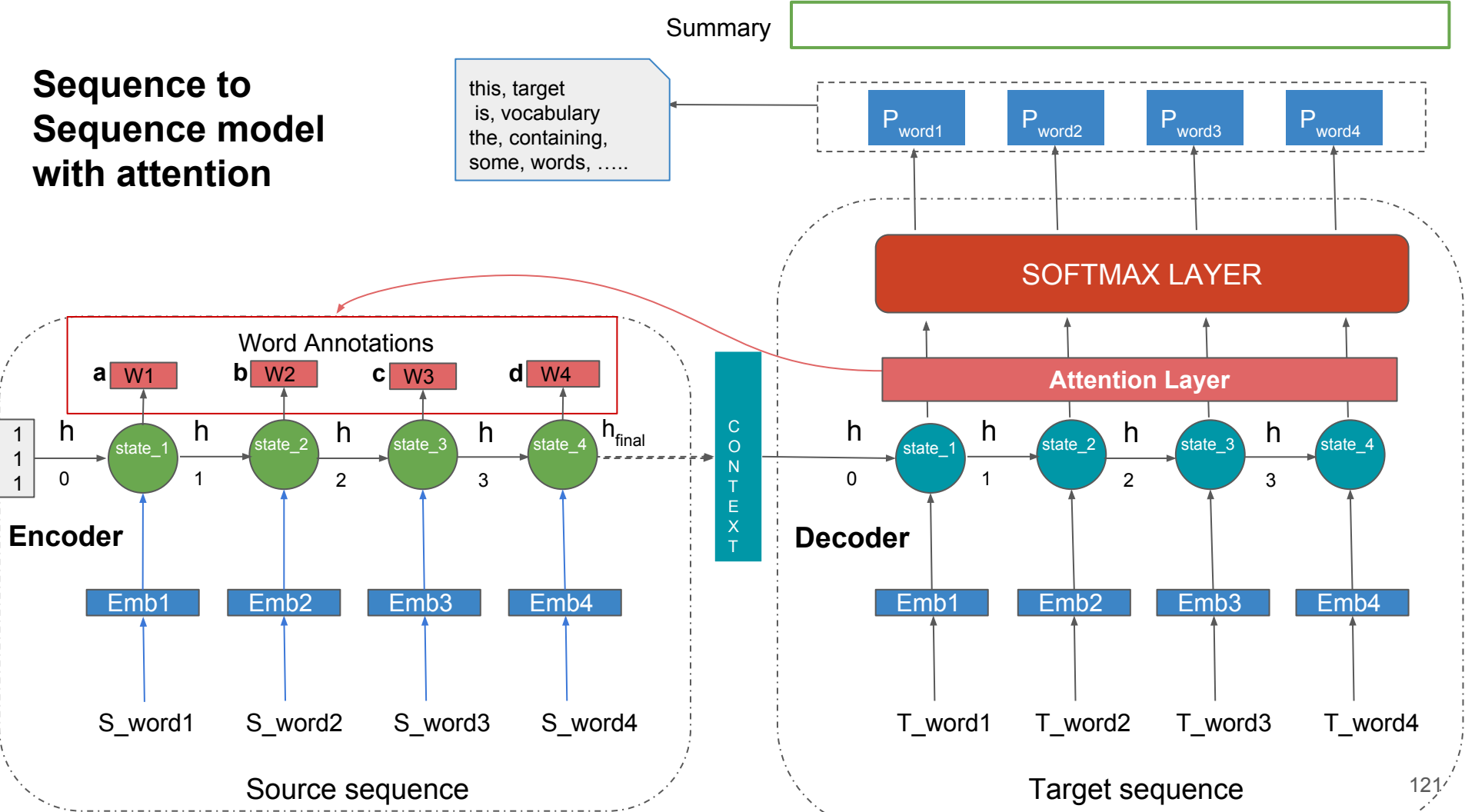

Sequence to Sequence model with attention

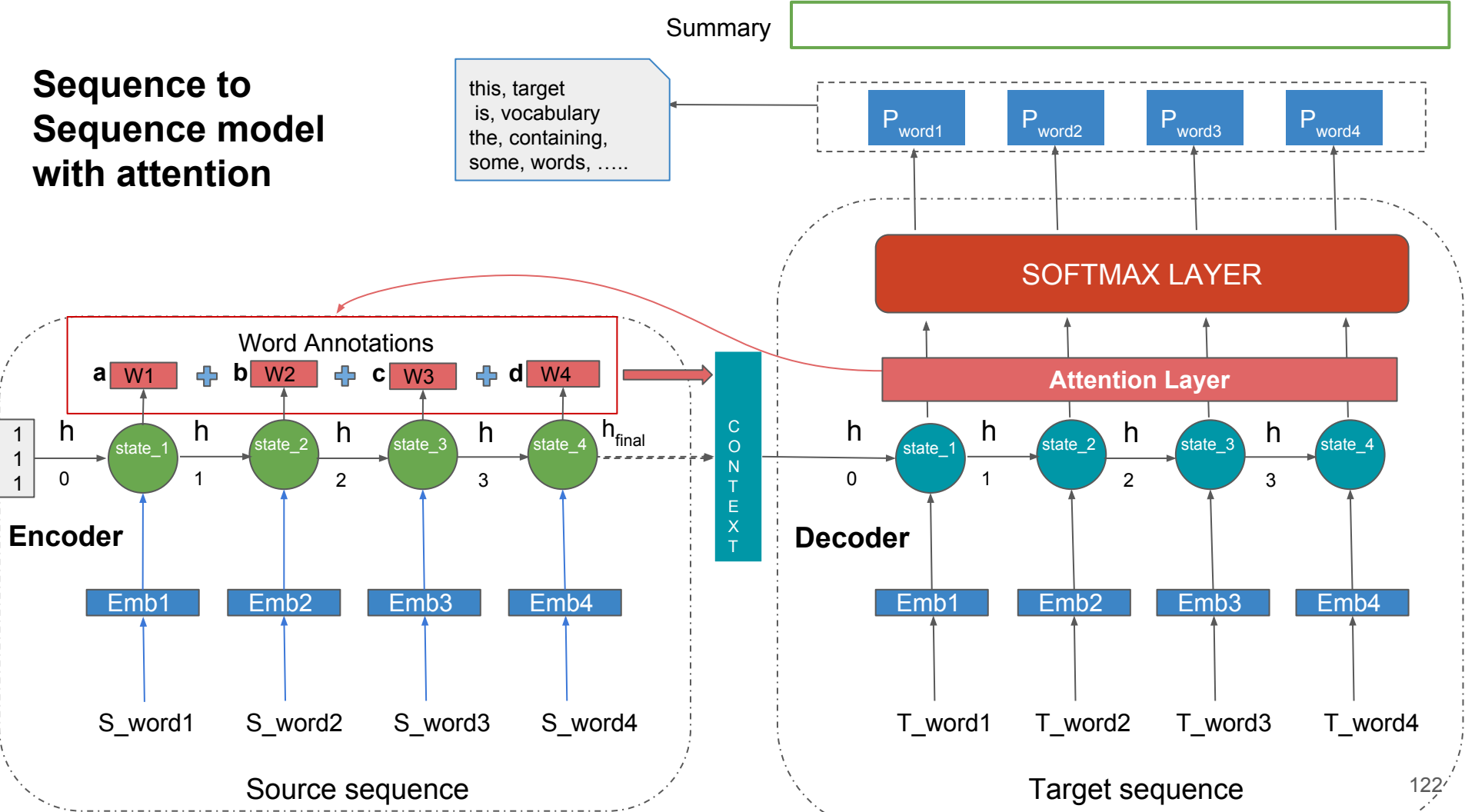

Sequence to Sequence model with attention

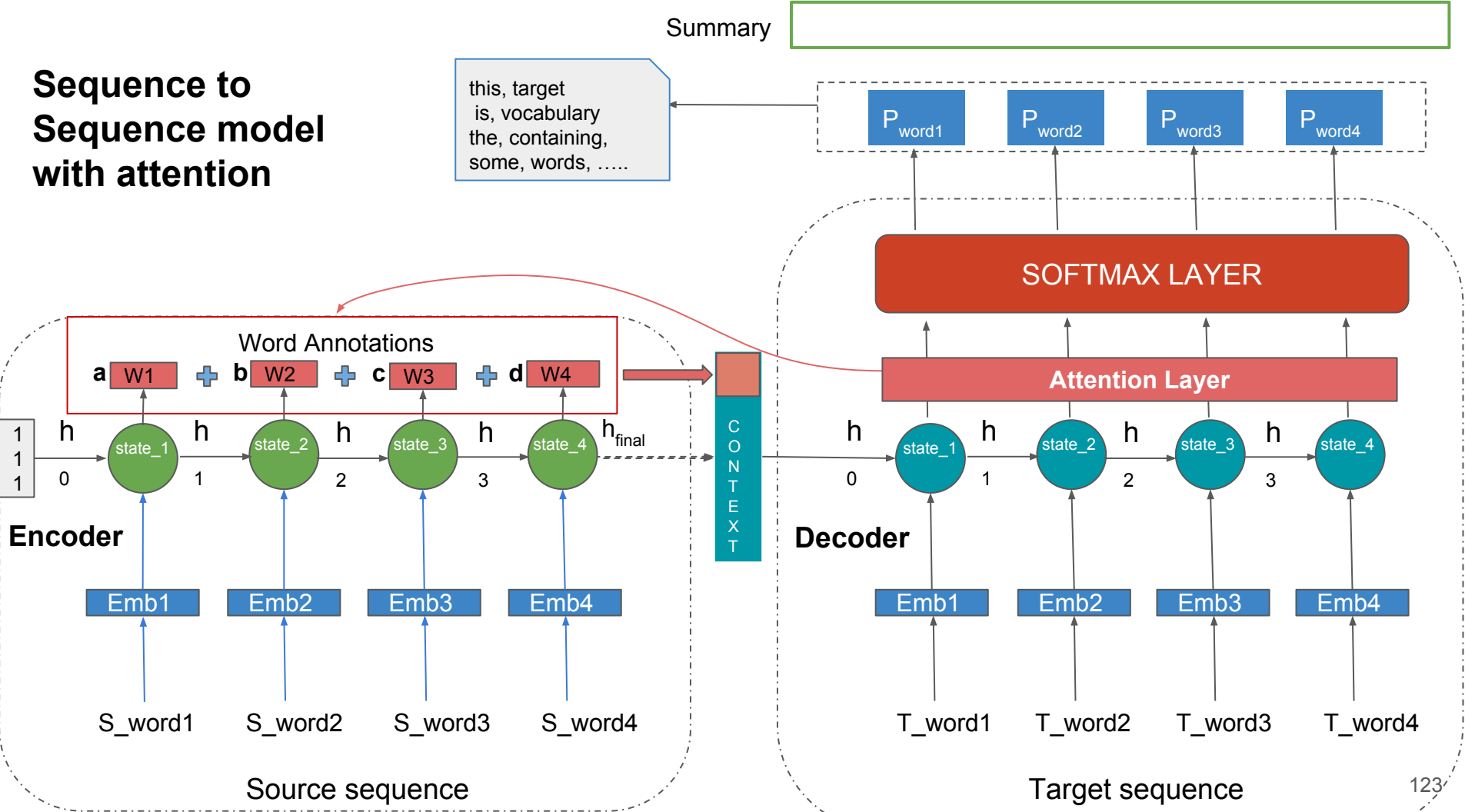

Sequence to Sequence model with attention

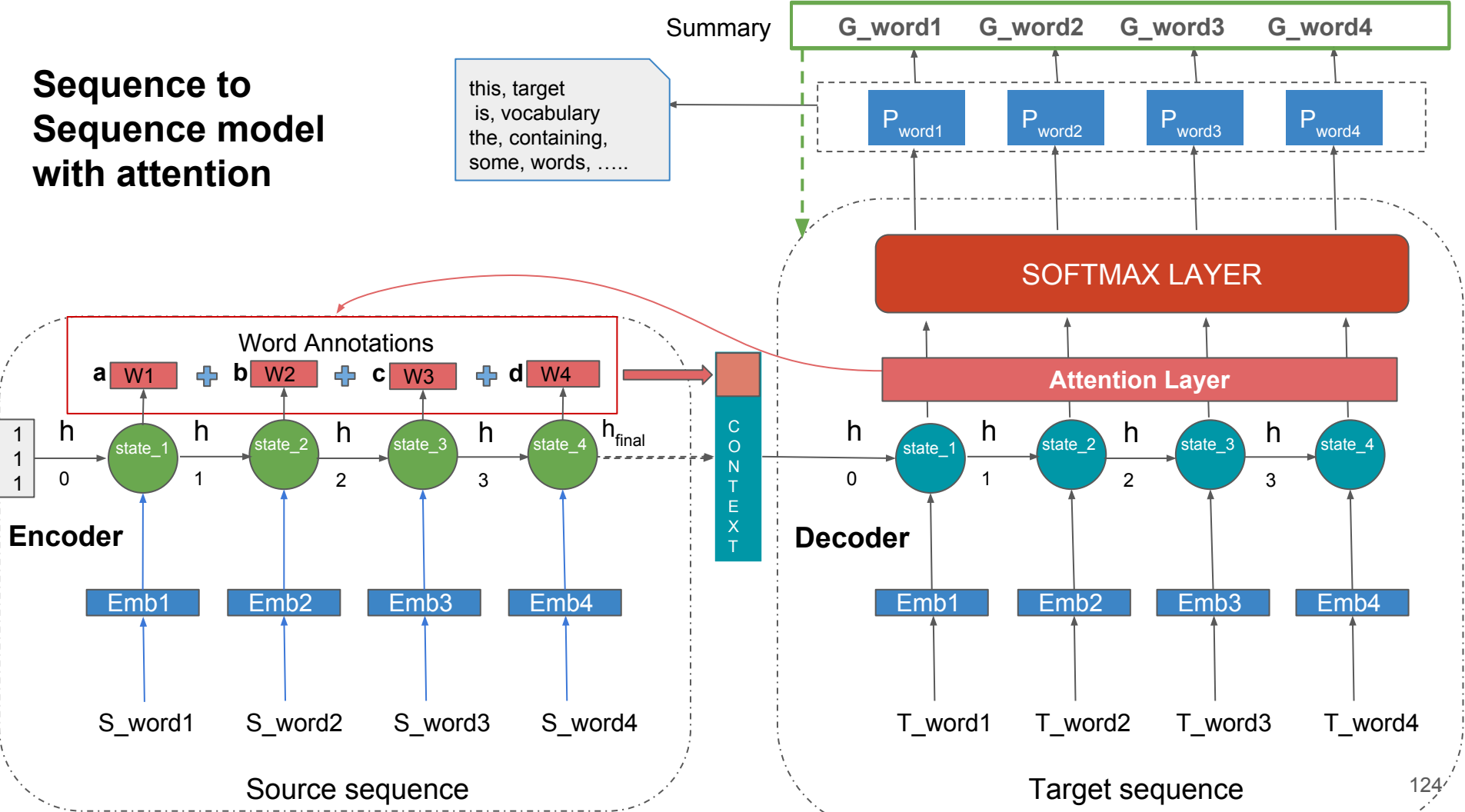

Evaluation

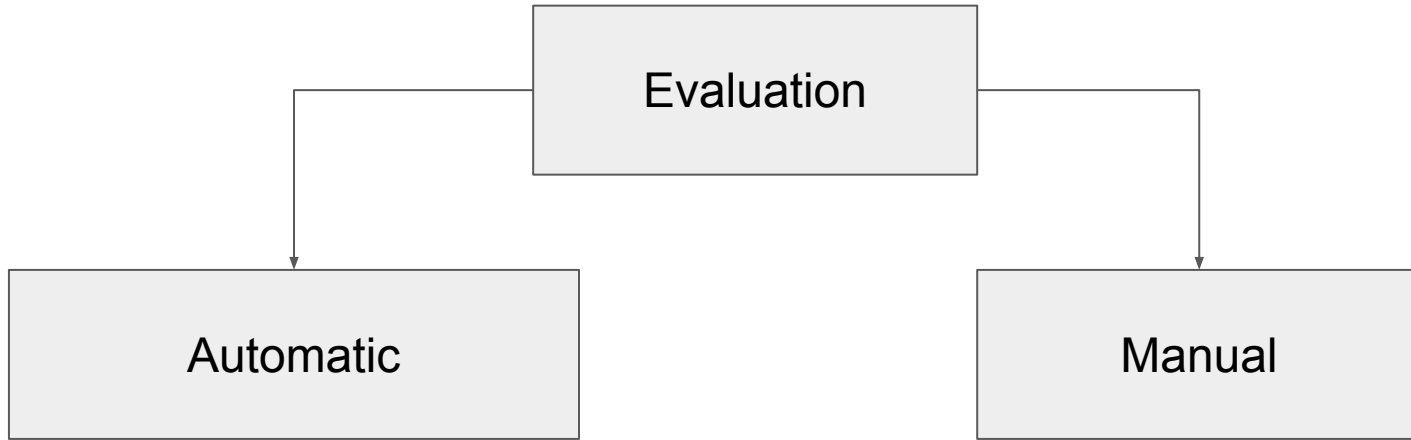

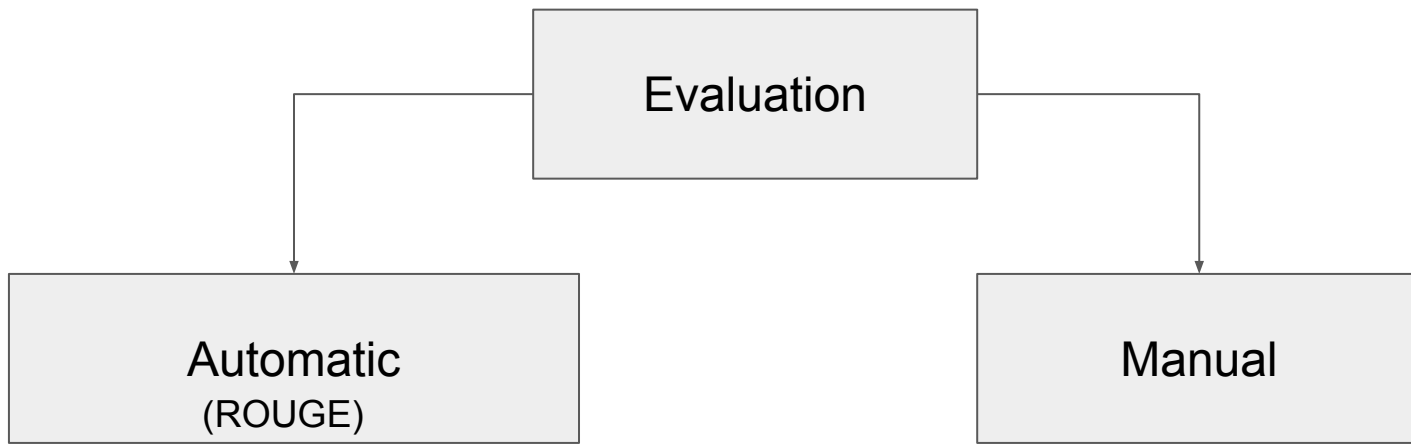

ROUGE for automatic evaluation

ROUGE for automatic evaluation

- ROUGE measures **n-gram overlaps** and **common subsequences** between automatic and ideal summaries

$$ROUGE - N = \frac{\sum_{S \in \{ReferenceSummaries\}} \sum_{gram_n \in S} Count_{match}(gram_n)}{\sum_{S \in \{ReferenceSummaries\}} \sum_{gram_n \in S} Count(gram_n)}$$

ROUGE for automatic evaluation

- ROUGE measures **n-gram overlaps** and **common subsequences** between automatic and ideal summaries

$$ROUGE - N = \frac{\sum_{S \in \{ReferenceSummaries\}} \sum_{gram_n \in S} Count_{match}(gram_n)}{\sum_{S \in \{ReferenceSummaries\}} \sum_{gram_n \in S} Count(gram_n)}$$

ROUGE for automatic evaluation

- ROUGE measures **n-gram overlaps** and **common subsequences** between automatic and ideal summaries

$$ROUGE - N = \frac{\sum_{S \in \{ReferenceSummaries\}} \sum_{gram_n \in S} Count_{match}(gram_n)}{\sum_{S \in \{ReferenceSummaries\}} \sum_{gram_n \in S} Count(gram_n)}$$

ROUGE for automatic evaluation

- ROUGE measures **n-gram overlaps** and **common subsequences** between automatic and ideal summaries

$$ROUGE - N = \frac{\sum_{S \in \{ReferenceSummaries\}} \sum_{gram_n \in S} Count_{match}(gram_n)}{\sum_{S \in \{ReferenceSummaries\}} \sum_{gram_n \in S} Count(gram_n)}$$

Training set	Size	ROUGE-1	ROUGE-2	ROUGE-L
Webis-TLDR-17	2 Million	17.87	6.11	15.78
Gigaword (Rush et al. 2015)	4 Million	31.33	11.81	36.38

ROUGE for automatic evaluation

- ROUGE measures **n-gram overlaps** and **common subsequences** between automatic and ideal summaries

$$ROUGE - N = \frac{\sum_{S \in \{ReferenceSummaries\}} \sum_{gram_n \in S} Count_{match}(gram_n)}{\sum_{S \in \{ReferenceSummaries\}} \sum_{gram_n \in S} Count(gram_n)}$$

Training set	Size	ROUGE-1	ROUGE-2	ROUGE-L
Webis-TLDR-17	2 Million	17.87	6.11	15.78
Gigaword (Rush et al. 2015)	4 Million	31.33 ?	11.81 ?	36.38 ?

Manual evaluation

Manual evaluation

- A test set of 200 examples containing 50 examples from each vertical

Manual evaluation

- A test set of 200 examples containing 50 examples from each vertical
- Binary categorization as relevant/irrelevant

Manual evaluation

- A test set of 200 examples containing 50 examples from each vertical
- Binary categorization as relevant/irrelevant
- Manual judgements vs ROUGE scores

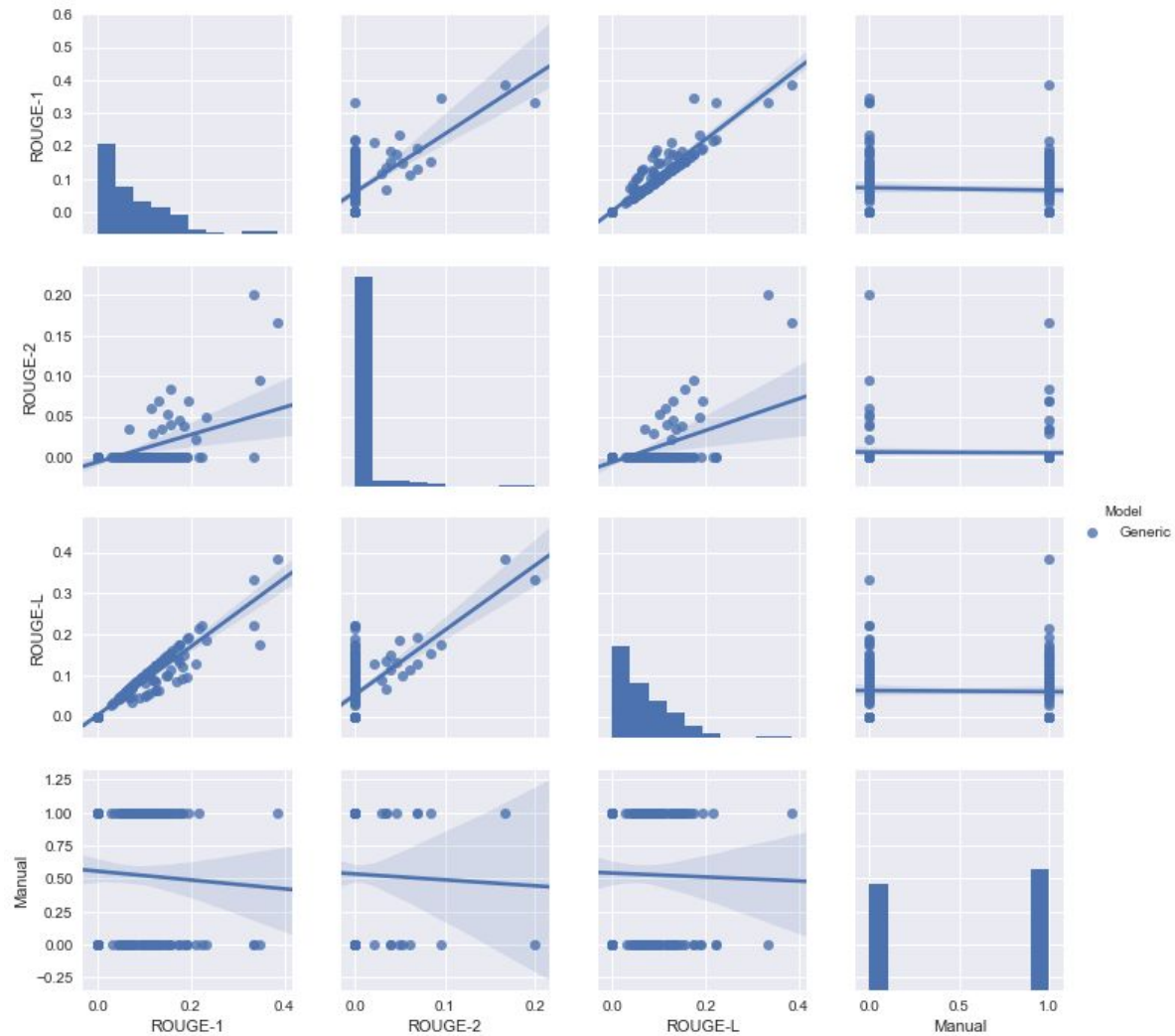

Manual judgement VS ROUGE

Manual judgement vs ROUGE

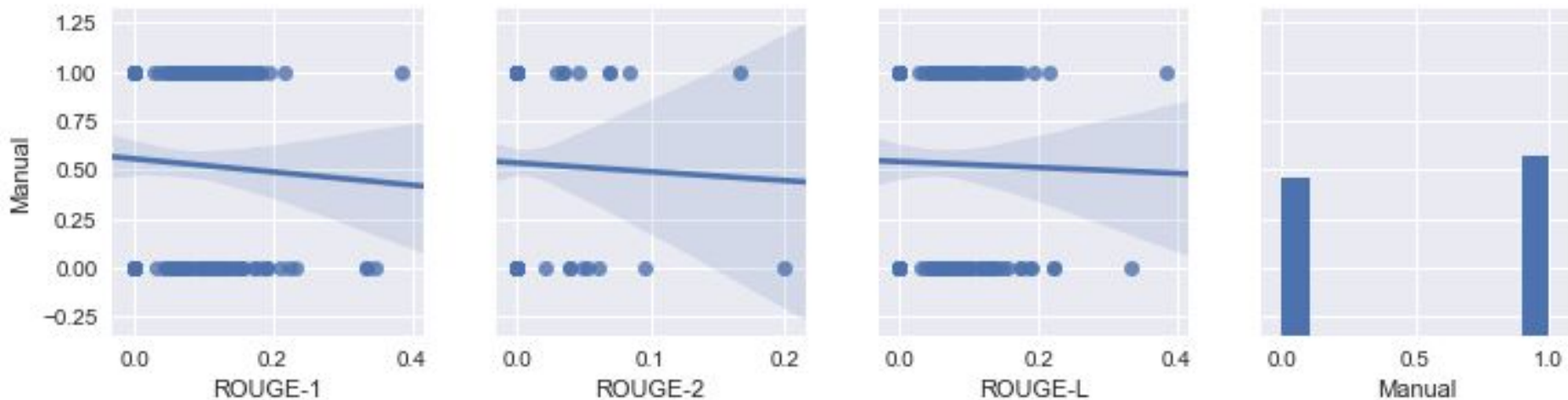

Manual evaluation (Cell values are in percentages)

Test set /Model	Questions (50)	Vulgar (50)	True(50) summaries	Generic (50)	All (200)
Ground truth	100	100	100	84	96
Questions (78,710)	31	50	28	16	31
Vulgar (299,145)	16	35	14	12	19.5
True Summaries (966,430)	44	54.9	36	30	41.29
Topic + tldr (729,042)	44	45	16	10	29
Topic (729,042)	58	47	50	30	48.5
Generic (2 Million)	67.3	62	52	34	53.5

Manual evaluation (Cell values are in percentages)

Test set /Model	Questions (50)	Vulgar (50)	True(50) summaries	Generic (50)	All (200)
Ground truth	100	100	100	84	96
Questions (78,710)	31	50	28	16	31
Vulgar (299,145)	16	35	14	12	19.5
True Summaries (966,430)	44	54.9	36	30	41.29
Topic + tldr (729,042)	44	45	16	10	29
Topic (729,042)	58	47	50	30	48.5
Generic (2 Million)	67.3	62	52	34	53.5 

Examples

Questions model

Content
True Summary
Generated Summary

ever since i watched one of the counselors at my camp play tron , i ' ve wanted to build it . the only problem is , i can ' t figure out which colors to build around . the group at my lgs that plays mainly modern is saying i should build r / g because it ' s the best , but i think the money that i would spend on a playset of [[grove of the burnwillows]] could be spent elsewhere and have a much bigger impact on the deck and the games i play with it . so my question to you guys is what non-r / g variants of tron could be viable in a competitive modern environment ?

what non-r / g variant should i build ?

what ' s the best build for a new player ?

Questions model

Content
True Summary
Generated Summary

ever since i watched one of the counselors at my camp play tron , i ' ve wanted to build it . the only problem is , i can ' t figure out which colors to build around . the group at my lgs that plays mainly modern is saying i should build r / g because it ' s the best , but i think the money that i would spend on a playset of [[grove of the burnwillows]] could be spent elsewhere and have a much bigger impact on the deck and the games i play with it . so my question to you guys is what non-r / g variants of tron could be viable in a competitive modern environment ?

what non-r / g variant should i build ?

what ' s the best build for a new player ?

Vulgar model

Content
True Summary
Generated Summary

just talked to catholic priest on a wedding . guys , have no mercy , please . the shit they preach is a mind killer for our civilization . religious people are fucking dumb , dumb fucks and they spread shit all over the place . i fucking spit on catholics . my whole family is religious and i can ' t have intellectual conversation on any subject with them . we can not tolerate any of this shit any longer . i ' m picking hitchens and the rest of dawkins for my holidays and i ' m going militant then . hoooly shit ! sorry for rant but the level of bullshit they can get over with is killing me .

religion = mental retardation .

religion is fucking stupid .

Vulgar model

Content
True Summary
Generated Summary

just talked to catholic priest on a wedding . guys , have no mercy , please . the shit they preach is a mind killer for our civilization . religious people are fucking dumb , dumb fucks and they spread shit all over the place . i fucking spit on catholics . my whole family is religious and i can ' t have intellectual conversation on any subject with them . we can not tolerate any of this shit any longer . i ' m picking hitchens and the rest of dawkins for my holidays and i ' m going militant then . hoooly shit ! sorry for rant but the level of bullshit they can get over with is killing me .

religion = mental retardation .

religion is fucking stupid .

True summaries

Content
True Summary
Generated Summary

alright so i just started seeing a girl i ' ve known for quite a while and things have been great . we get along really well and just genuinely enjoy each other ' s time . only hiccup is i enjoy smoking copious weed and she well , she hates weed . her ex boyfriend apparently let weed take over his life . he was standing her up to go smoke , ditching work to go find weed , and just fucking around basically is what it sounds like . well she blames the weed for his short comings and now judges everyone based on the fact that they smoke weed . she doesn ' t care about tobacco , or alcohol either just weed . i know common sense says to just tell her i smoke a ton and tell her it doesn ' t impact my life negatively and i still get my shit down . idk . basically i ' m looking for helpful stories or advice for me if you ' ve been in a similar situation . we aren ' t super serious at all , and she ' s moving states in about two months so it ' s not a huge deal but i also want to enjoy our time together while she still lives here

been dating a new girl who hates weed because her last boyfriend couldn ' t handle smoking and his life . now i ' m torn between telling her how much i smoke and how often or just hiding it until she moves away . any help is greatly appreciated

i want to tell a girl i smoke a lot , she hates weed , what do i do ?

Topic + tl;dr

Content

True Topic : True Summary

Generated Topic : Generated Summary

yesterday i tried lsd for the first time . i first took half of a 110ug tab thinking that i shouldnt overdo it for the first time , about 4 minutes later i took the other half (thought that 55ug wouldnt be enough) . half an hour later , nothing . an hour later , a bit light headed but zero visuals . two hours later , i feel a bit happier and i see a glimpse of a pattern on our table move but that ' s about it for the visuals . about 3.5 hours in i took another tab thinking i would finally get some more visuals . . . nothing . i tested the lsd and it came out positive . so did i get some seriously underdosed tabs or did i fuck up by not taking the whole tab at once in the start or do i have a freakishly high tolerance or something ?

Did I get underdosed tabs ? : tried lsd for the first time yesterday , first took half a tab , then the other half 4 minutes later . ended up jusy a bit light headed so 3.5 hours in i took another tab , still got pretty much no visuals .

Question about LSD : i ' m a noob and i ' d like to know if i did it or not .

Topic only

Content
True Topic
Generated Topic

Guaranteed Promotion or Possible Future Career Path ? : my boss offered me a position she wants to fill this week , while i ' m also in consideration for a position with her boss .

need advice on negotiating a promotion .

Generic model

Content
True Summary
Generated Summary

I finished Path of Daggers earlier this month and took a break to read I Am Pilgrim (I HIGHLY recommend) and I am now ready to start my journey into book 9 . One thing , I ' ve forgotten a few plot threads . I can ' t search for them as possible spoilers , so what do I need to know going in ? Oh , and SPOILERS for those not up to here and please , no spoilers for me . I love this series to much for it to be ruined . I know Faile has been taken but I ' m not sure about the other main characters whereabouts and smaller character plots . If

where are the characters at and what are they hoping to do ? People refreshing my memory would be greatly appreciated .

What do I need to know to start my journey into book 9 ?

Existing Problems

Failure to replicate facts

Content
True Summary
Generated Summary

my wife (teacher) constantly complains about how she can ' t stand her job , the kids are disrespectful , etc . and how much she hates it . i know my wife , and i know she wants me to say " sweetie why don ' t you just quit ? " but i ' m not going to say that under any circumstances . however , i did tell her that i will support her leaving if she has a backup job or if she decides to go back to school (that will help advance her career) . i also said that i would pay for her schooling . her response is that she does not want to go back to school . it ' s getting to the point where she talks about how much she hates work everyday . it completely ruins the end of the day , as half the time it ends in her crying . i ' m not sure what to do

My (32 / m) wife (32 / f) complains about her job and wants me to tell her it ' s okay to quit , but I ' m not going to , how do I handle this ? : wife hates her job and wants me to tell her to quit . i ' m not going to tell her to quit , but i also don ' t know what to do .

I [27 / m] don ' t know how to tell my wife [28 / f] that I don ' t want to quit her job . : wife is mad because i don ' t want to quit .

Repeating words

Content
True Summary
Generated Summary

it was around the holidays a few years ago and i had started smoking for the first time . being somewhat forced to spend " quality time " with my family , i decided to smoke a blunt before going . i get to my parents house , i ' m at a solid [9] and my sweet , little , 80 year old grandma was sitting on the couch . i took a seat next to her and she tried to lean her head on my shoulder , being too short she rested it on my bicep . she patted my leg before looking up at me saying " you ' re so high " . i nearly jump out of my skin , and look at her a bit side-ways because i had put on new clothes , perfume and even brushed my teeth before coming over . just before i could get the words " how did you know " out of my mouth , she smiled at me , " so high i can ' t rest my head on your shoulder . " i laughed nervously and adjusted accordingly so she could lean her head on me .

went to a family gathering super baked , sat next to my grandma who said " you ' re so high " referring to my height because she couldn ' t rest her head on my shoulder when i sat up straight . scared the shit outta me .

i got high as fuck and got high as fuck .

Repeating words

Content
True Summary
Generated Summary

it was around the holidays a few years ago and i had started smoking for the first time . being somewhat forced to spend " quality time " with my family , i decided to smoke a blunt before going . i get to my parents house , i ' m at a solid [9] and my sweet , little , 80 year old grandma was sitting on the couch . i took a seat next to her and she tried to lean her head on my shoulder , being too short she rested it on my bicep . she patted my leg before looking up at me saying " you ' re so high " . i nearly jump out of my skin , and look at her a bit side-ways because i had put on new clothes , perfume and even brushed my teeth before coming over . just before i could get the words " how did you know " out of my mouth , she smiled at me , " so high i can ' t rest my head on your shoulder . " i laughed nervously and adjusted accordingly so she could lean her head on me .

went to a family gathering super baked , sat next to my grandma who said " you ' re so high " referring to my height because she couldn ' t rest her head on my shoulder when i sat up straight . scared the shit outta me .

i got high as fuck and got high as fuck .

Conclusion & Future work

- **Webis-TLDR-17 corpus** for summarization from the social media domain (Reddit)

- **Webis-TLDR-17 corpus** for summarization from the social media domain (Reddit)
 - Amazon product reviews, Clueweb/Wikipedia, Blogs

- **Webis-TLDR-17 corpus** for summarization from the social media domain (Reddit)
 - Amazon product reviews, Clueweb/Wikipedia, Blogs
- Exploring the effectiveness and limitations of **sequence-to-sequence** models

- **Webis-TLDR-17 corpus** for summarization from the social media domain (Reddit)
 - Amazon product reviews, Clueweb/Wikipedia, Blogs
- Exploring the effectiveness and limitations of **sequence-to-sequence** models
 - Convolutional networks instead of recurrent

- **Webis-TLDR-17 corpus** for summarization from the social media domain (Reddit)
 - Amazon product reviews, Clueweb/Wikipedia, Blogs
- Exploring the effectiveness and limitations of **sequence-to-sequence** models
 - Convolutional networks instead of recurrent
 - Fine tuning the summary generation process

- **Webis-TLDR-17 corpus** for summarization from the social media domain (Reddit)
 - Amazon product reviews, Clueweb/Wikipedia, Blogs
- Exploring the effectiveness and limitations of **sequence-to-sequence** models
 - Convolutional networks instead of recurrent
 - Fine tuning the summary generation process
 - Bridging the gap between extractive and abstractive

- **Webis-TLDR-17 corpus** for summarization from the social media domain (Reddit)
 - Amazon product reviews, Clueweb/Wikipedia, Blogs
- Exploring the effectiveness and limitations of **sequence-to-sequence** models
 - Convolutional networks instead of recurrent
 - Fine tuning the summary generation process
 - Bridging the gap between extractive and abstractive
- Alternate evaluation method

Thank You!